

# -1987定制衬衫.工艺培训-

# 目录

CONTENTS

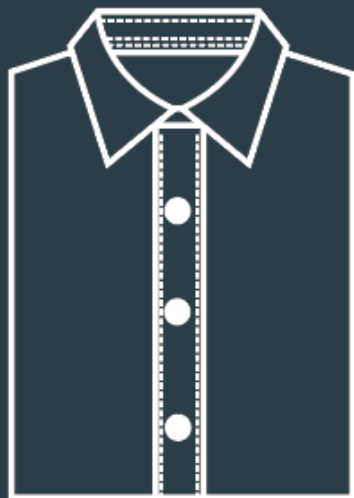

1

1987.定制衬衫生产简介

2

1987.定制衬衫制作流程

3

1987.定制男装衬衫缝制工艺

4

1987.定制女装衬衫缝制工艺

5

1987.定制衬衫生产质量标准



**01**

# 定制衬衫生产简介

# 01：衬衫生产简介

鲁泰制衣工序拥有先进的高档衬衣生产线，辅助吊挂、流水槽等自动输送系统实现精益生产，并建有标准化实验室，执行国标等质量标准，产品的合格率始终保持在**99.9%**以上；主要生产中高档色织纯棉衬衫，液氨潮交联、液氨后焙烘、成衣免烫衬衫等，产品销往美国、日本、意大利、德国、英国、俄罗斯等**30**多个国家和地区；应用先进的CAD设计系统、3D效果，并与ERP进行数据集成，不断提升产品品质和效率；**建有定制智能制造中心，拥有3D可视化下单平台，引进国际领先水平的MTM自动打版系统、智能化自动裁床，生产管控高定系统，做到衬衣从接单到生产、发货全过程控制的信息化、关键生产环节的自动化，极大缩短了生产周期，确保了产品整体质量，年产量80万件。**





02

定制衬衫工艺流程

# 02: 1987.定制衬衫流程

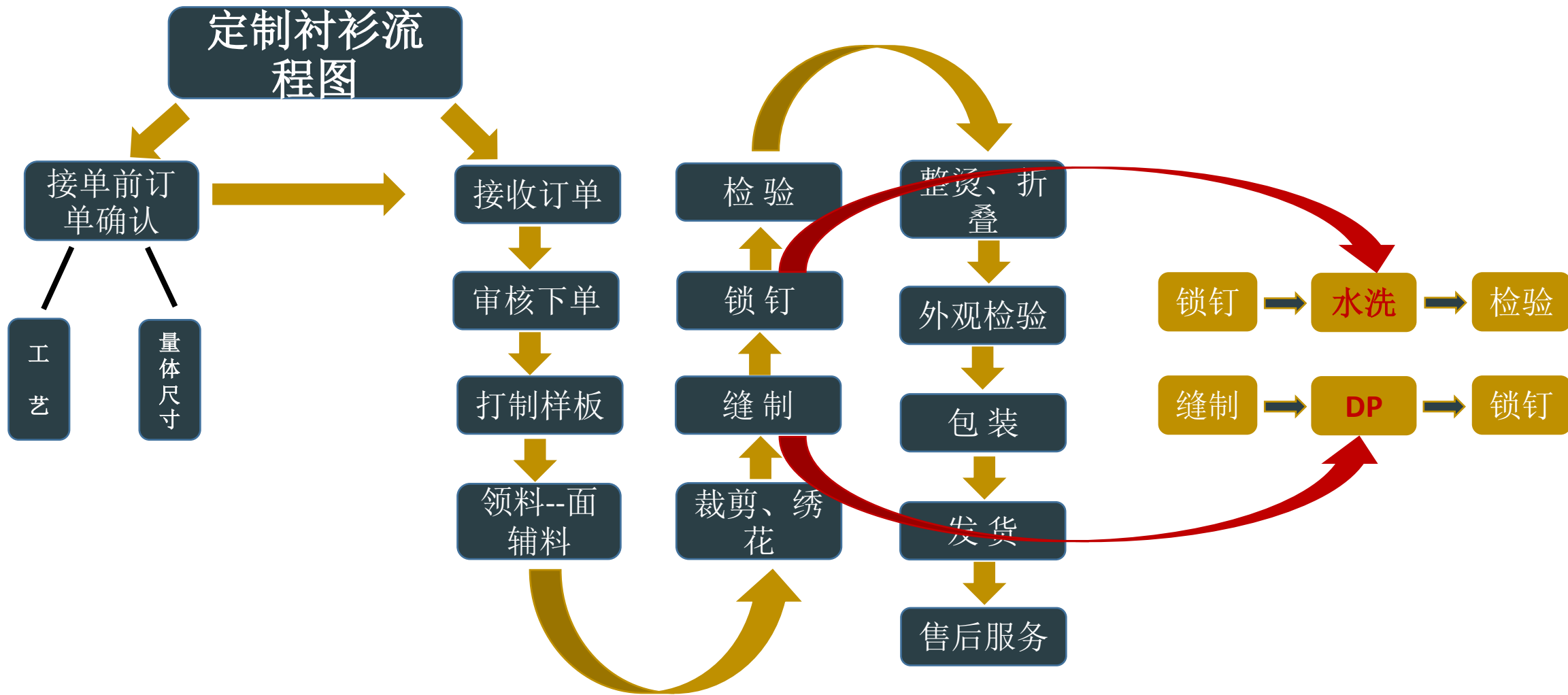

# 03

## 男装衬衫缝制工艺

- (1) 衬衫各部位名称
- (2) 领型工艺设计
- (3) 袖口工艺设计
- (4) 前片工艺设计
- (5) 口袋工艺设计
- (6) 袖褶、下摆弧度、后片款式工艺设计
- (7) 过肩裁剪方式、袖袂、礼服拼贴工艺设计
- (8) 织带、配色工艺
- (9) 主唛（商标）、锁钉位置
- (10) 刺绣字体、图案、位置工艺设计
- (11) 免烫级别、嵌条工艺
- (12) 辅料（纽扣、缝线、绣花线）

# 03: 男装衬衫缝制工艺

## (1) 衬衫各部位名称

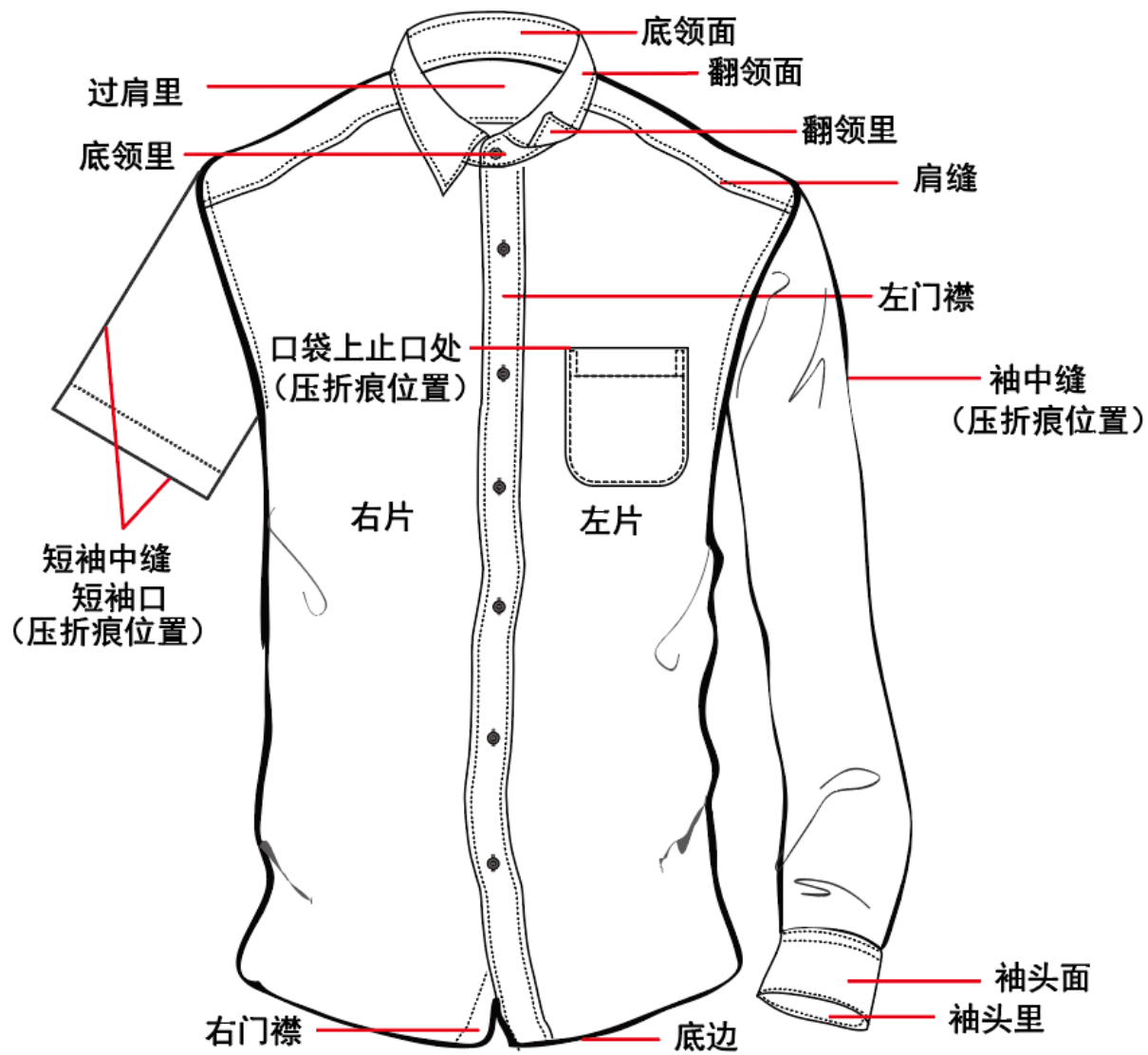

# 03: 男装衬衫缝制工艺

## (1) 衬衫各部位名称

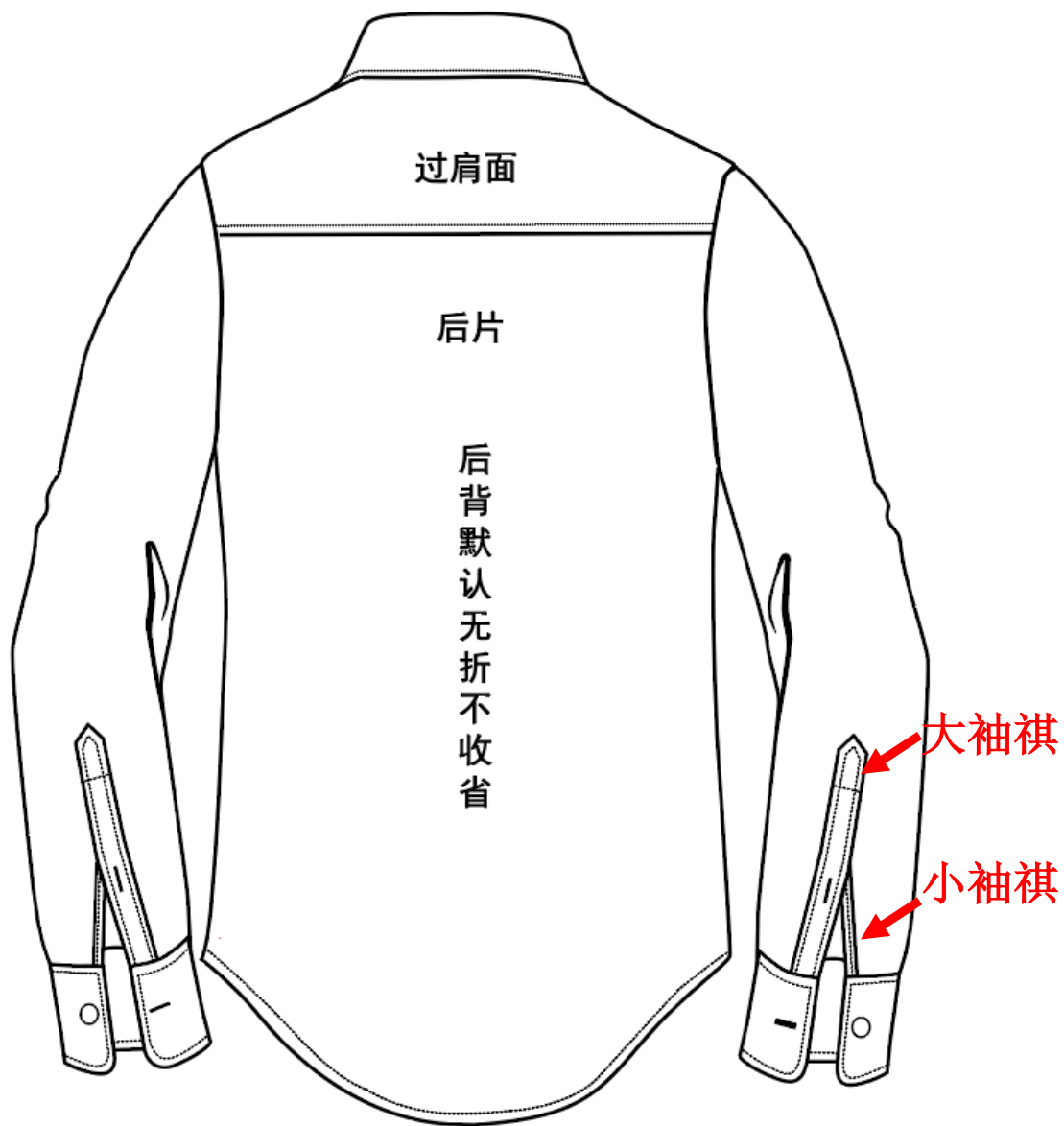

# 03: 男装衬衫缝制工艺

男装：明线宽0.1CM、0.3CM、0.5CM

2

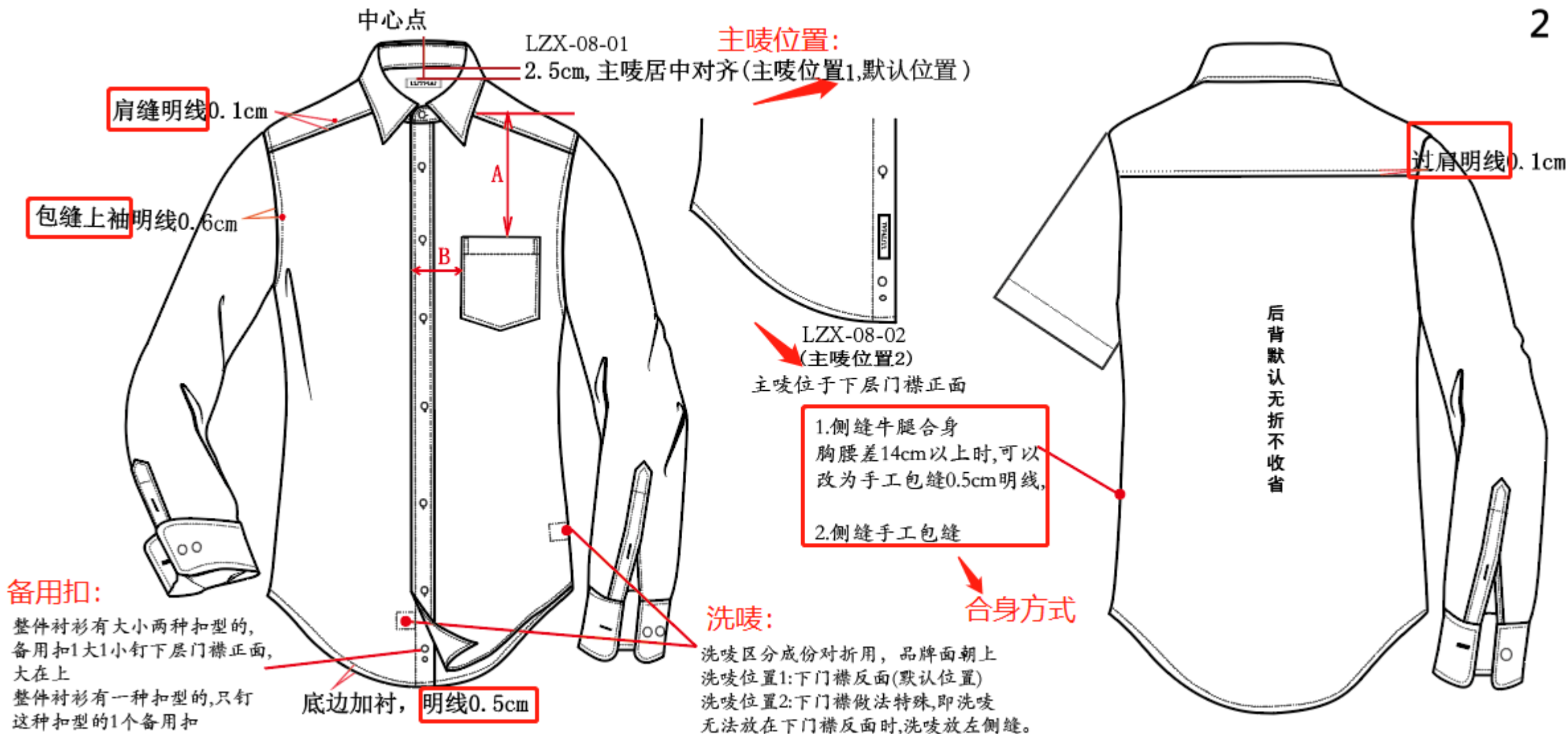

### 领型



# 03: 男装衬衫缝制工艺

## (2) 领型工艺设计

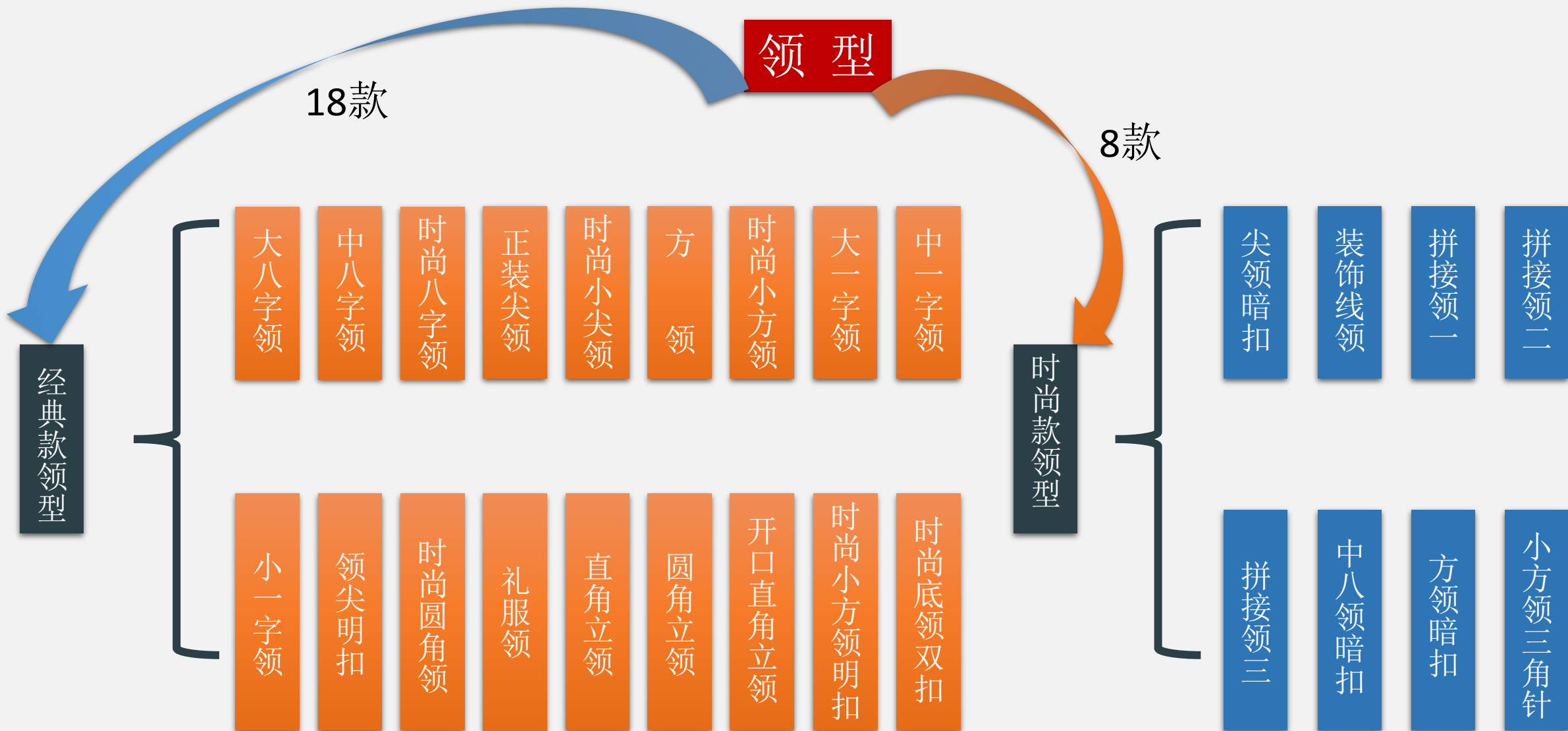

# 03: 男装衬衫缝制工艺

## (2) 领型工艺设计



# 03: 男装衬衫缝制工艺

## (2) 领型工艺设计

**领型：（普通款式：15道工序）**

经典款领型：18款，区分高、中、低，共计41款。

时尚款领型：8款，区分高、中、低，共计22款。

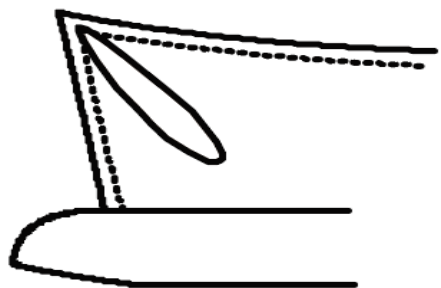

内插领

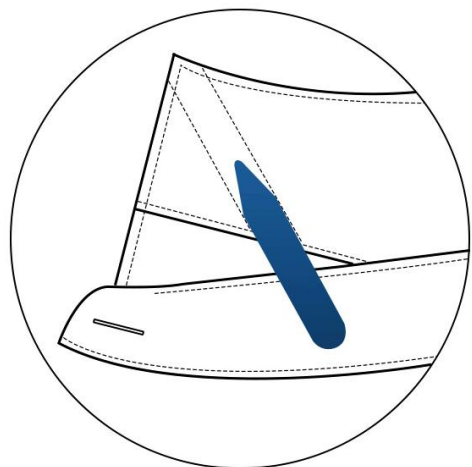
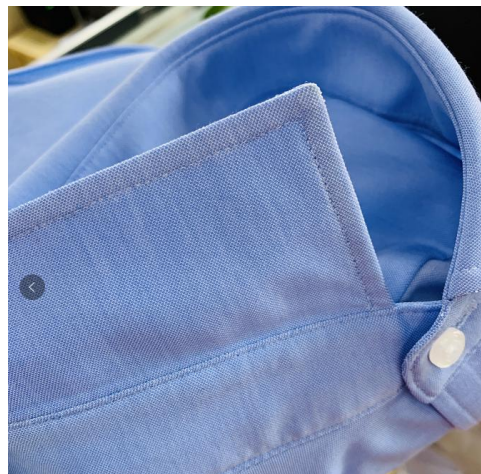

外插片



| 编号         | 底领中宽 | 翻领中宽 | 领尖长 |
|------------|------|------|-----|
| LZX-01-01G | 3.5  | 4.5  | 7.7 |
| LZX-01-01Z | 3.1  | 4.1  | 7.3 |
| 其他工艺       | 内外插片 |      |     |
| LZX-01-01A | 2.7  | 3.7  | 6.9 |

大八字领

# 03: 男装衬衫缝制工艺

## (2) 领型工艺设计

特殊领型介绍:

立领



LZX-01-10Z

01-09Z

礼服领



# 03：男装衬衫缝制工艺

## (2) 领型工艺设计

特殊领型介绍：[1987定制领型照片](#)



# 袖头



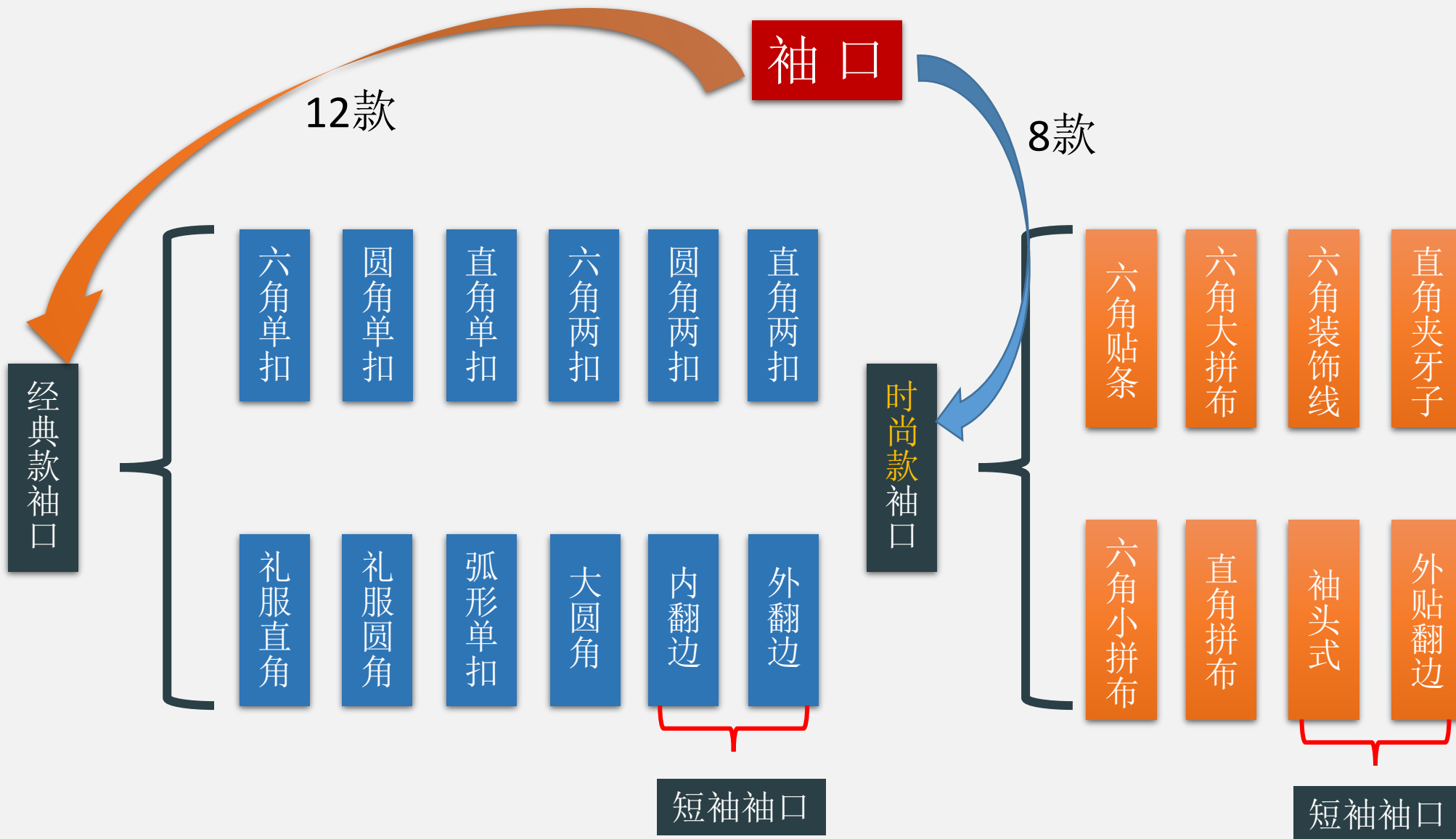

# 03: 男装衬衫缝制工艺

## (3) 袖头工艺设计

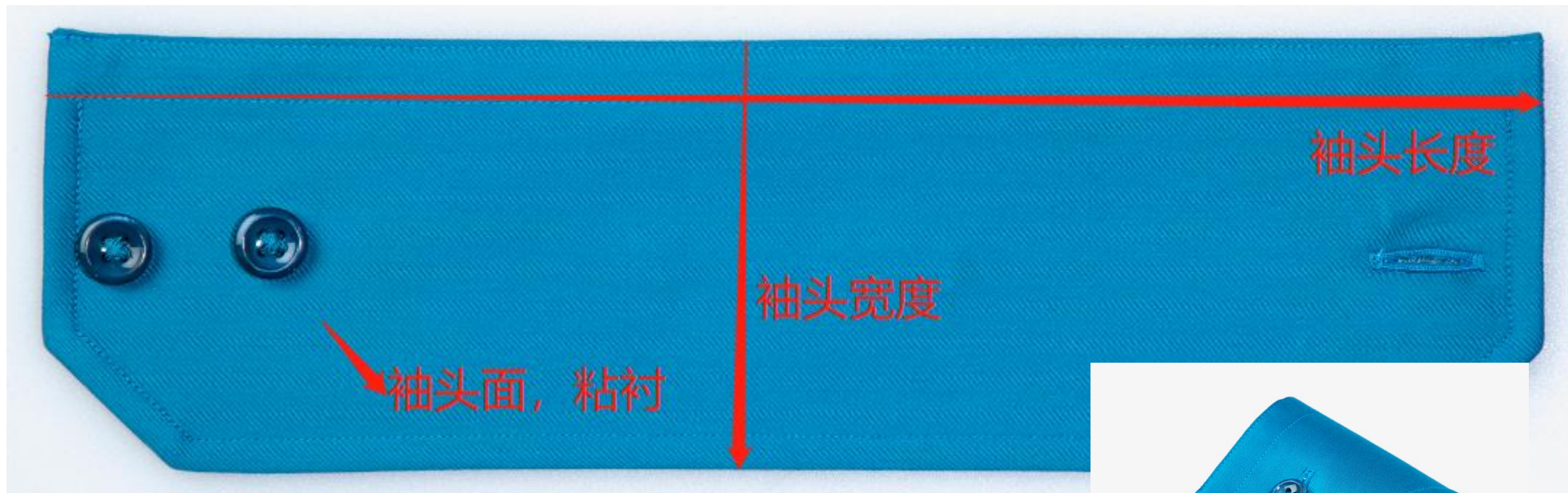

# 03：男装衬衫缝制工艺

## (3) 袖口工艺设计

袖头：（普通款式9道工序） [1987定制](#)  
[袖头照片](#)

经典款袖头：10款；短袖口2款  
时尚款袖头：6款；短袖口2款

袖口共4个宽度  
区分单扣、双扣



### 短袖口

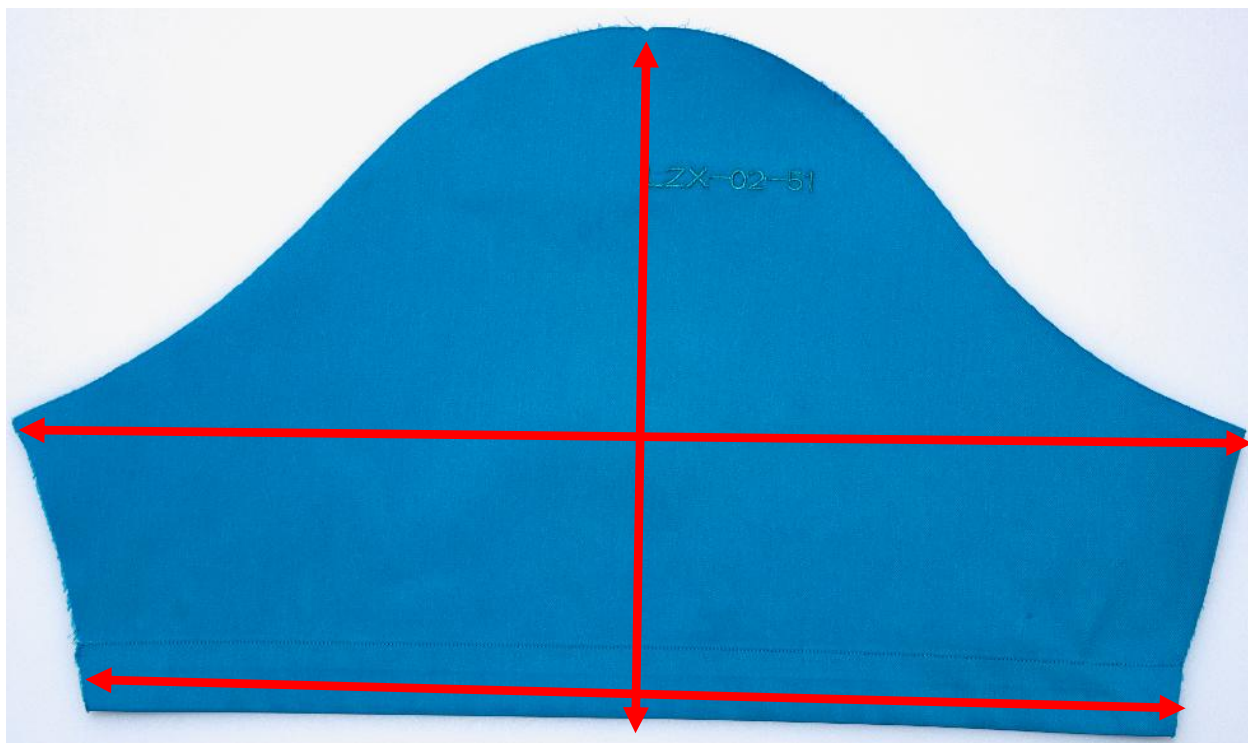

# 03: 男装衬衫缝制工艺

## (4) 前片工艺设计

前片

右片



左片

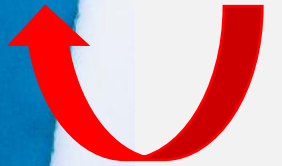

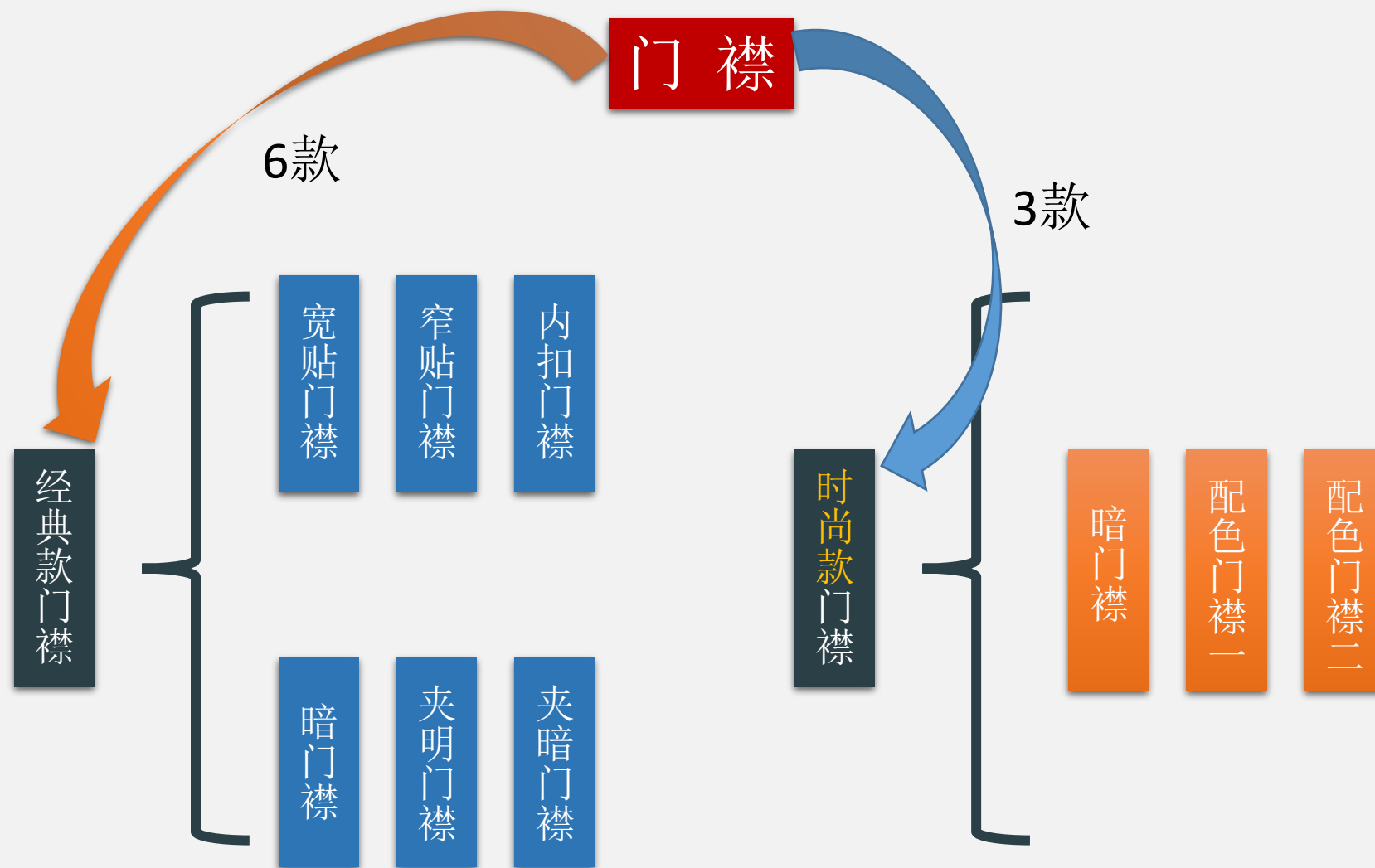

# 03: 男装衬衫缝制工艺

## (4) 前片工艺设计

门襟：（普通款式10道工序） **1987定制**

### 门襟照片

经典款门襟： 7款  
时尚款门襟： 3款

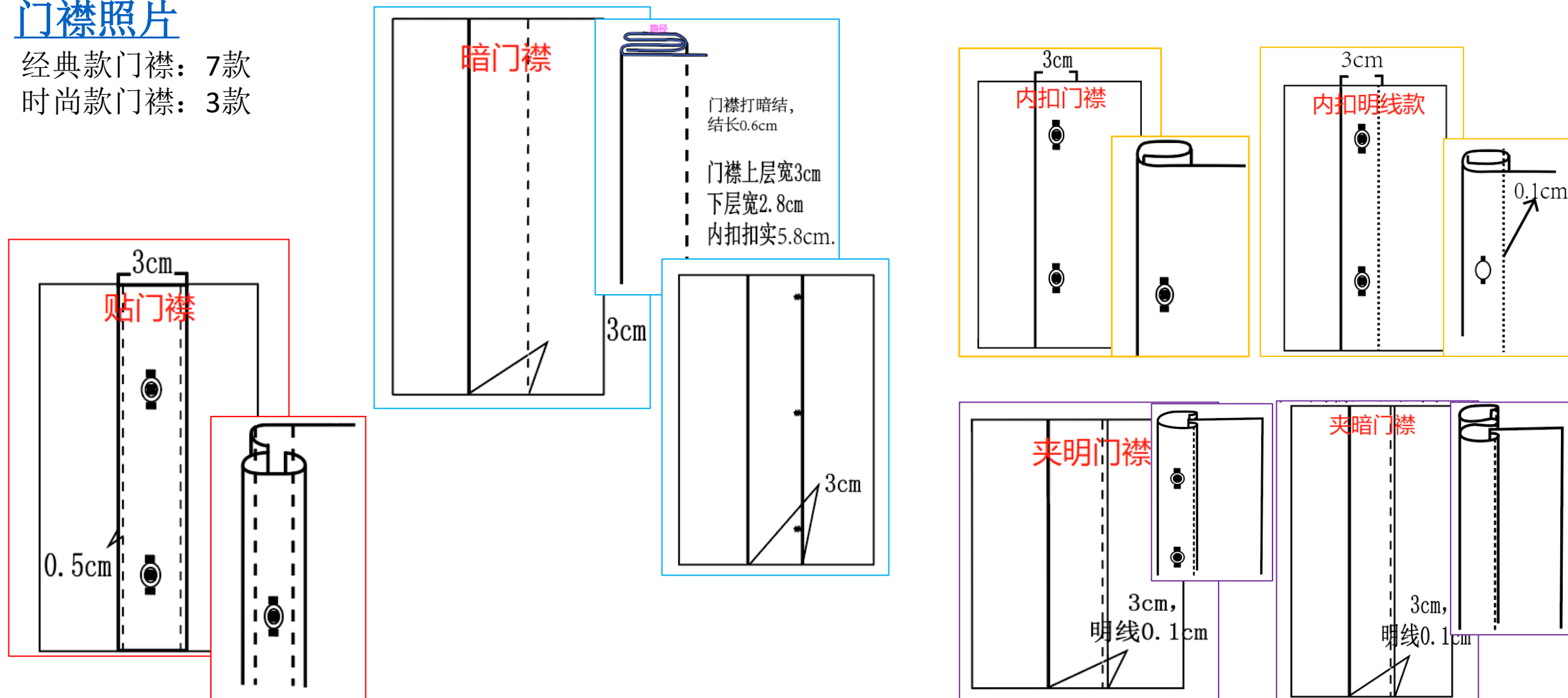

# 03: 男装衬衫缝制工艺

## (4) 前片工艺设计

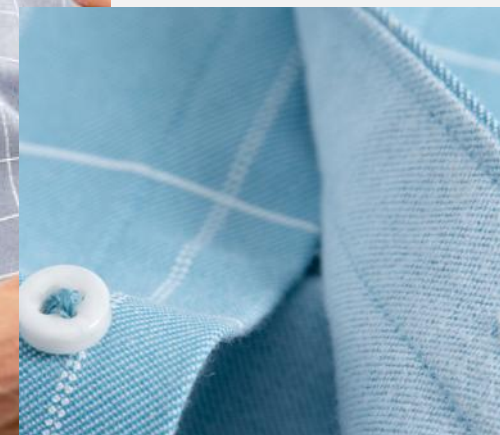

### 门襟扣眼数量

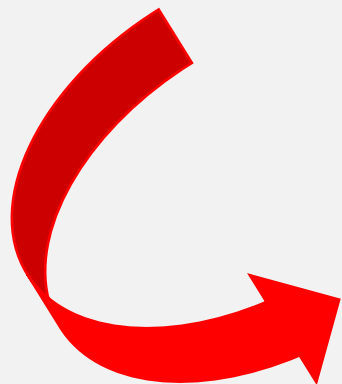

#### 后身长尺寸 (门襟扣眼不含领头扣眼)

|                |
|----------------|
| 1、66CM及以下：5个   |
| 2、67CM-74CM：6个 |
| 3、75CM-83CM：7个 |
| 4、84CM及以上：8个   |

#### 前身长尺寸 (门襟扣眼不含领头扣眼)

|                |
|----------------|
| 1、67CM及以下：5个   |
| 2、68CM-75CM：6个 |
| 3、76CM-84CM：7个 |
| 4、85CM及以上：8个   |

门襟最后一个扣眼距底边的距离  
最小不能小于：  
最大不能大于等于：**19CM**  
如有超出范围的需与客户确认。



不适合DP面料的门襟：

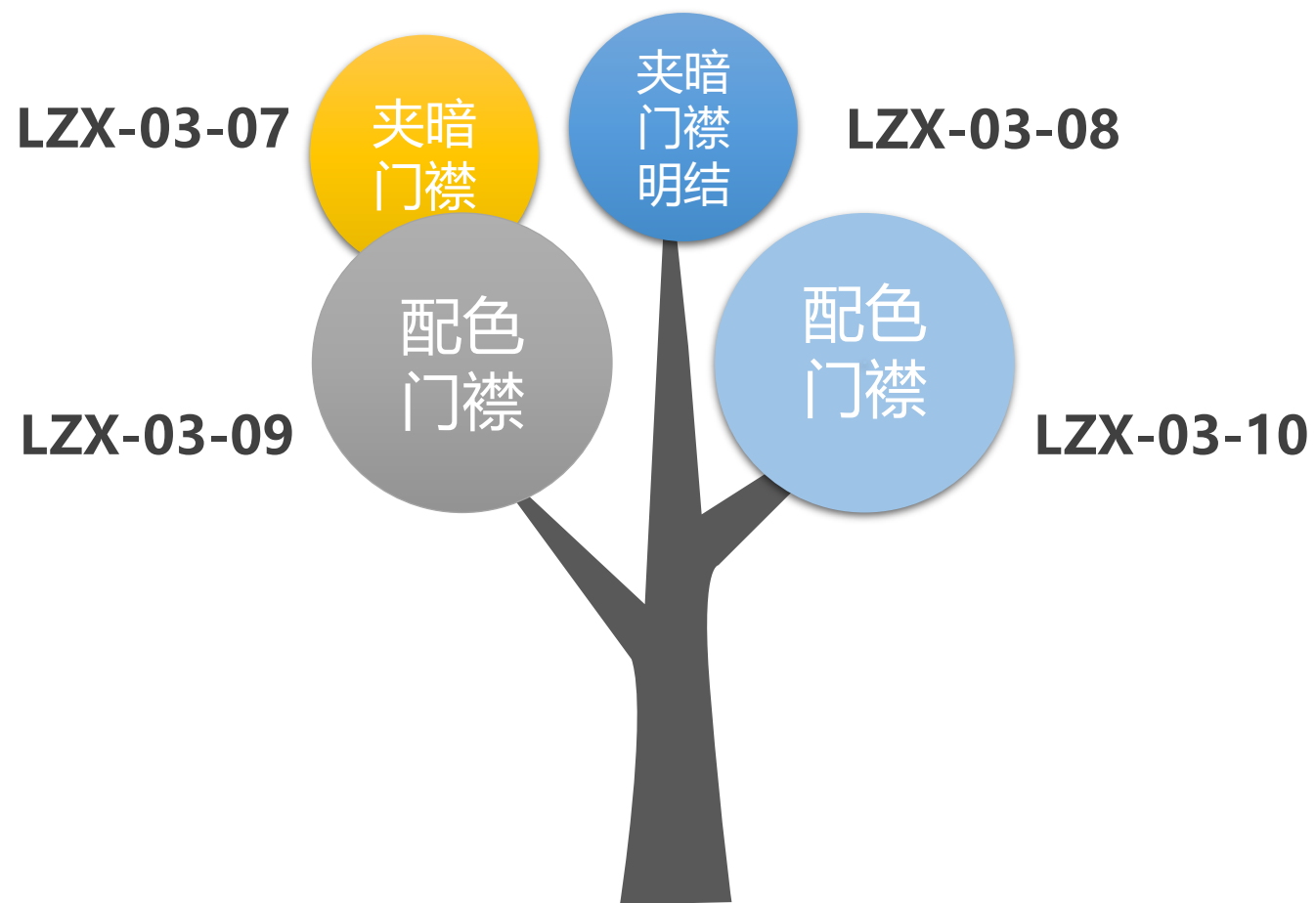

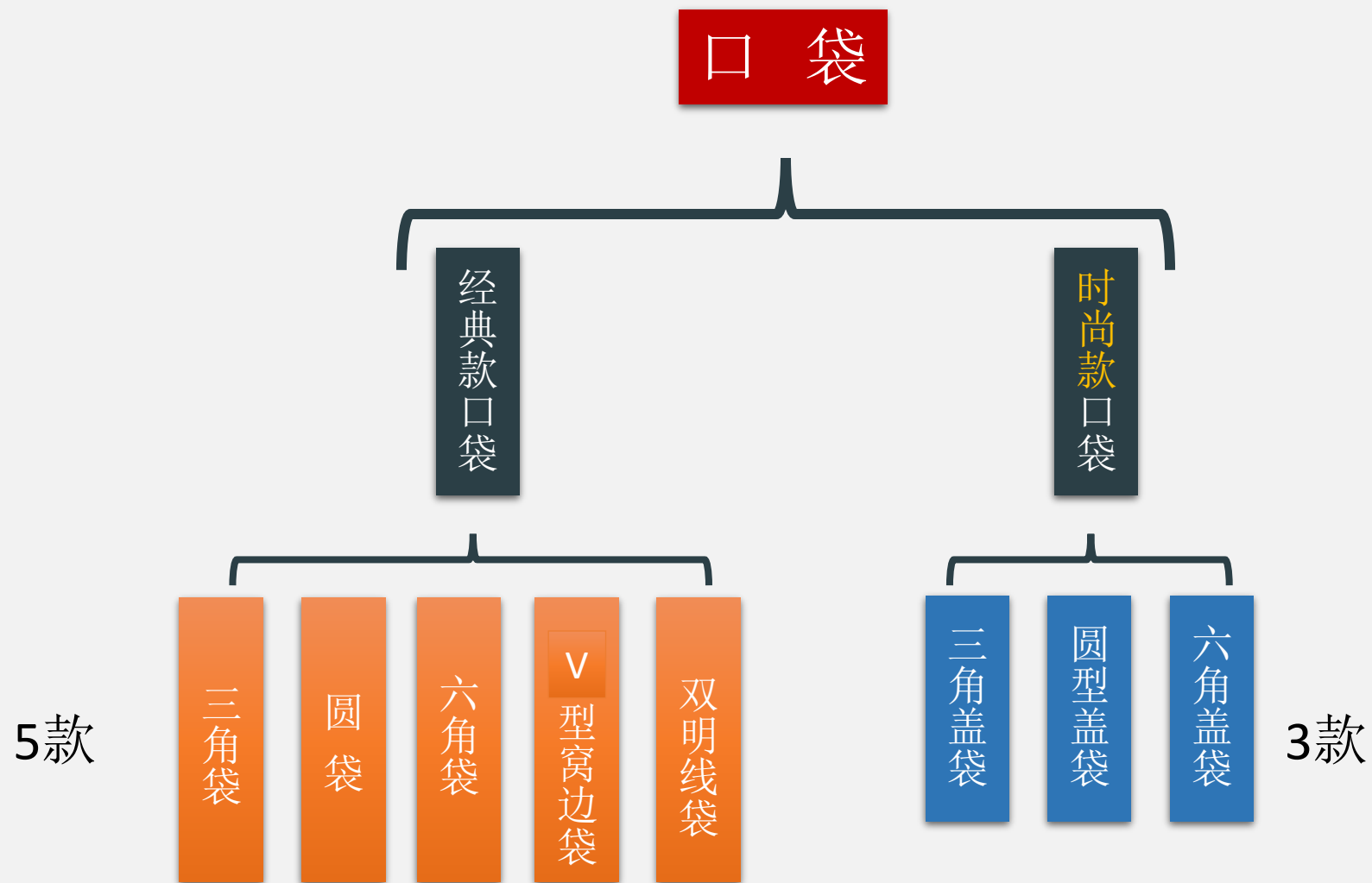

## 03：男装衬衫缝制工艺

### (5) 口袋工艺设计



口袋位置



# 03: 男装衬衫缝制工艺

## (5) 口袋工艺设计

鲁泰智能制造男衬衫合身版规格表 (B放松量14)

| 尺寸    | 165/80Y | 165/84Y | 165/88Y | 170/88A | 170/92A | 170/96A | 170/98A | 175/96A | 175/98A | 175/100A | 185/100C | 185/104C |
|-------|---------|---------|---------|---------|---------|---------|---------|---------|---------|----------|----------|----------|
| 口袋位置a | 19      | 19      | 19      | 19.5    | 19.5    | 20      | 20      | 20      | 20      | 20       | 21.5     | 21.5     |
| 口袋位置b | 6       | 6       | 6       | 6.5     | 6.5     | 7       | 7       | 7       | 7       | 7        | 7.5      | 7.5      |
| 口袋尺寸c | 10      | 10      | 10      | 10.5    | 10.5    | 11      | 11      | 11      | 11      | 11       | 12.5     | 12.5     |
| 口袋尺寸d | 12      | 12      | 12      | 12.5    | 12.5    | 13      | 13      | 13      | 13      | 13       | 13.5     | 13.5     |



|       |         |
|-------|---------|
| 尺寸    | 165/80Y |
|       | 37      |
| 口袋位置a | 18.5    |
| 口袋位置b | 6       |
| 口袋尺寸c | 9.5     |
| 口袋尺寸d | 11.5    |

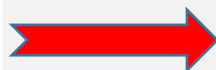

紧身、修身、合身、  
宽松四个版型中，只有紧身版中  
一个号型尺寸有所不同。

# 03: 男装衬衫缝制工艺

## (5) 口袋工艺设计

口袋: 4道工序

经典款口袋: 5款

时尚款口袋: 3款

[1987定制口袋照片](#)

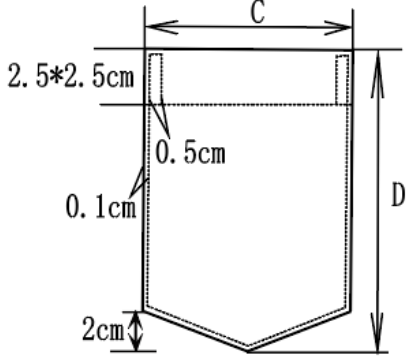
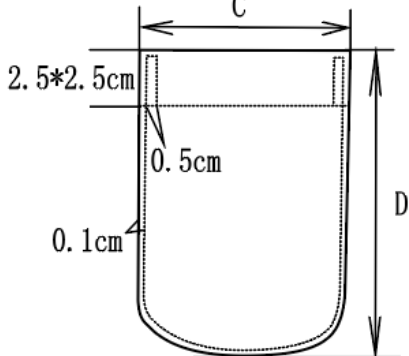
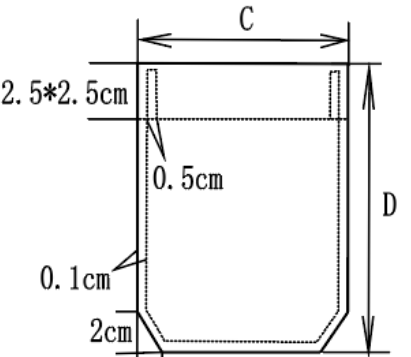
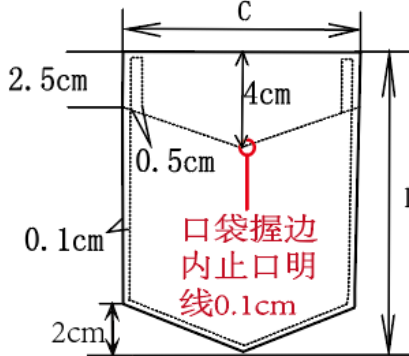
| LZX-04-01三角袋                                                                        | LZX-04-02圆袋                                                                          |
|-------------------------------------------------------------------------------------|--------------------------------------------------------------------------------------|
|   |   |
| LZX-04-03六角袋                                                                        | LZX-04-04V型握边袋                                                                       |
|  |  |

# 03: 男装衬衫缝制工艺

## (5) 口袋工艺设计

适用于休闲款式

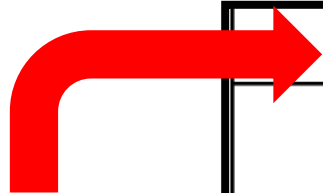

|                                                                                                                                                                                                                                            |                                                                                                                                                                                                                                                        |
|--------------------------------------------------------------------------------------------------------------------------------------------------------------------------------------------------------------------------------------------|--------------------------------------------------------------------------------------------------------------------------------------------------------------------------------------------------------------------------------------------------------|
| <p>LZX-04-05双明线袋</p> <p>1*3cm<br/>0.1cm<br/>C<br/>0.5cm<br/>D<br/>2cm<br/>2cm<br/>0.5cm<br/>双明线0.1+0.5cm</p>                                                                                                                               | <p>LZX-04-06三角盖袋</p> <ul style="list-style-type: none"> <li>*袋盖锁大眼,口袋握边上钉大扣.</li> <li>*袋盖面粘8007衬.</li> <li>*口袋口上1cm处钉袋盖.</li> </ul> <p>0.5cm<br/>C<br/>1*3cm<br/>D<br/>0.1cm<br/>2cm<br/>C+0.5cm<br/>0.5cm<br/>4.5cm<br/>2cm<br/>1.5cm<br/>0.5cm</p>   |
| <p>LZX-04-07圆型盖袋</p> <ul style="list-style-type: none"> <li>*袋盖锁大眼,口袋握边上钉大扣.</li> <li>*袋盖面粘8007衬.</li> <li>*口袋口上1cm处钉袋盖.</li> </ul> <p>C<br/>1*3cm<br/>D<br/>0.1+0.5cm<br/>C+0.5cm<br/>0.5cm<br/>5cm<br/>0.8cm<br/>1.5cm<br/>0.1+0.5cm</p> | <p>LZX-04-08六角盖袋</p> <ul style="list-style-type: none"> <li>*袋盖锁大眼,口袋握边上钉大扣.</li> <li>*袋盖面粘8007衬.</li> <li>*口袋口上1cm处钉袋盖.</li> </ul> <p>0.5cm<br/>C<br/>1*3cm<br/>D<br/>C+0.5cm<br/>0.5cm<br/>4.5cm<br/>1.5cm<br/>1cm<br/>0.1+0.5cm<br/>2cm<br/>2cm</p> |

# 03: 男装衬衫缝制工艺

## (6) 袖褶、下摆弧度、后片款式工艺设计

### 袖褶

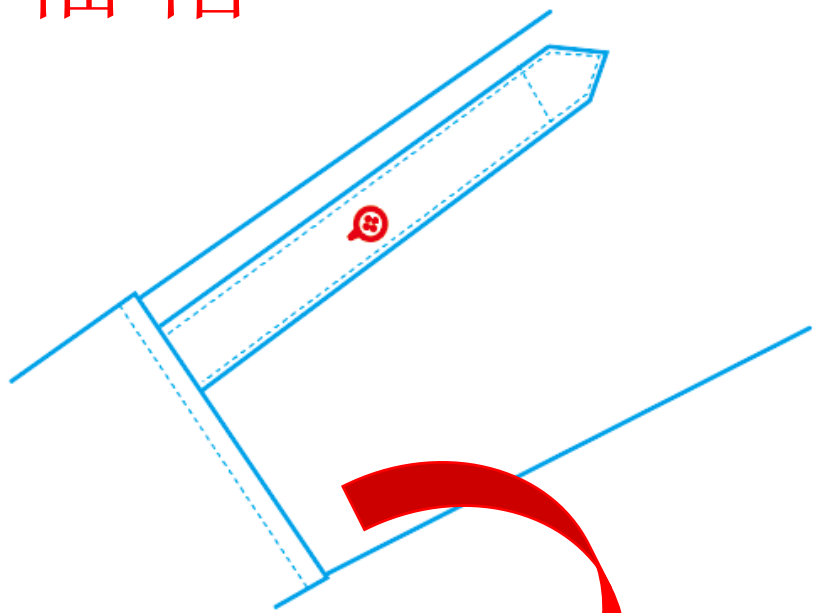

LZX-120-00  
袖口无褶



小臂围很粗，喜欢宽松的客户不建议无褶款。

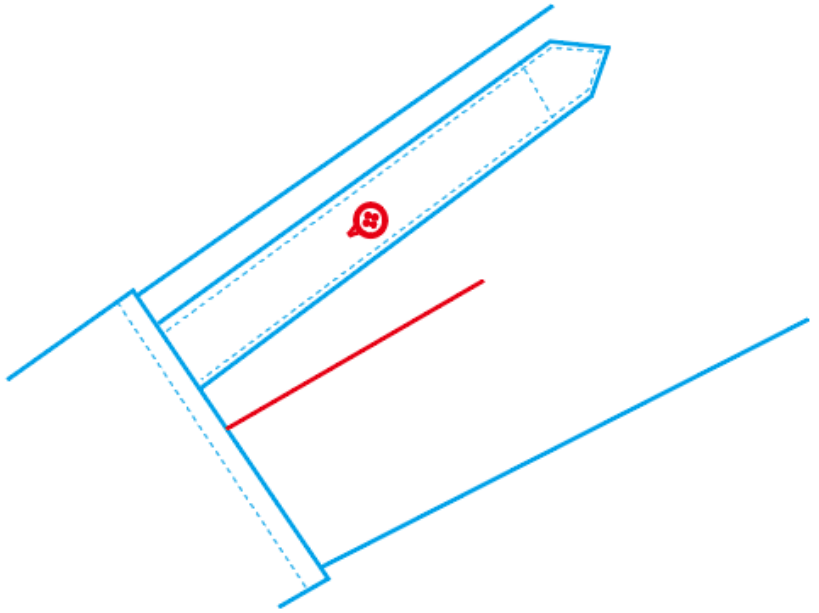

LZX-120-01  
袖口单褶

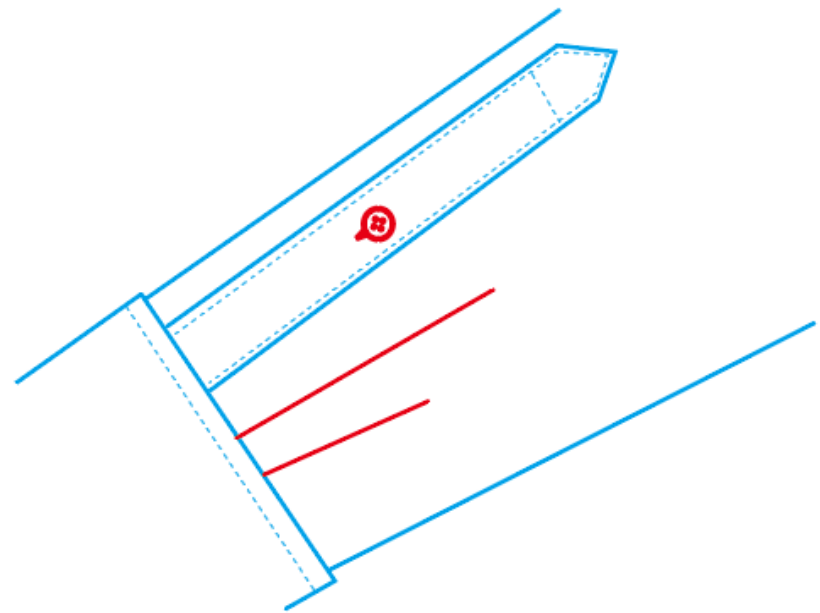
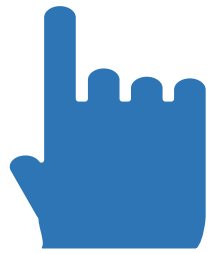

LZX-120-02  
袖口双褶

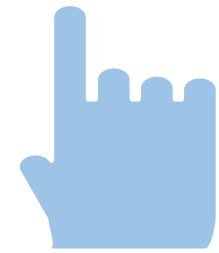

## 03：男装衬衫缝制工艺

(6) 袖褶、下摆弧度、后片款式工艺设计

### 袖褶



款式风格、穿着舒适度、体型特征

# 03: 男装衬衫缝制工艺

(6) 袖褶、下摆弧度、后片款式工艺设计

## 下摆弧度

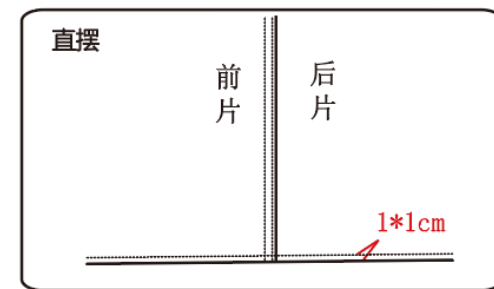
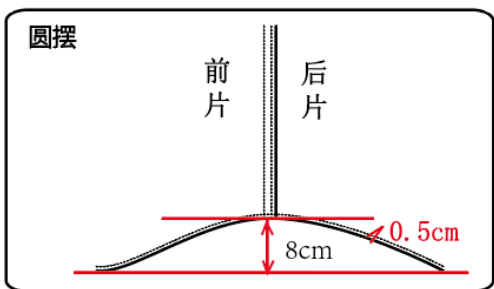
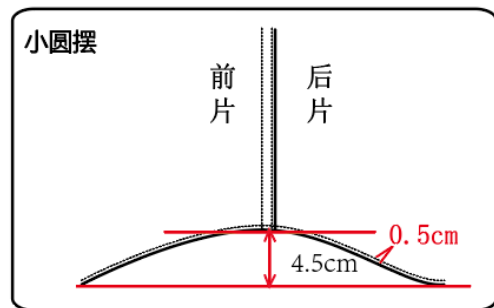

# 03: 男装衬衫缝制工艺

## (6) 袖褶、下摆弧度、后片款式工艺设计

### 后片款式



无褶不收省

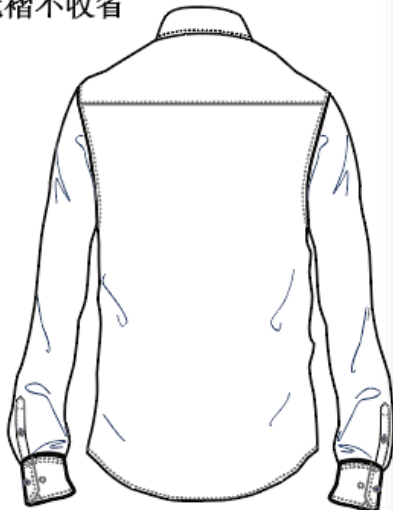

LZX-17-01

边褶不收省



LZX-17-03

无褶收双省



LZX-17-02

中褶不收省

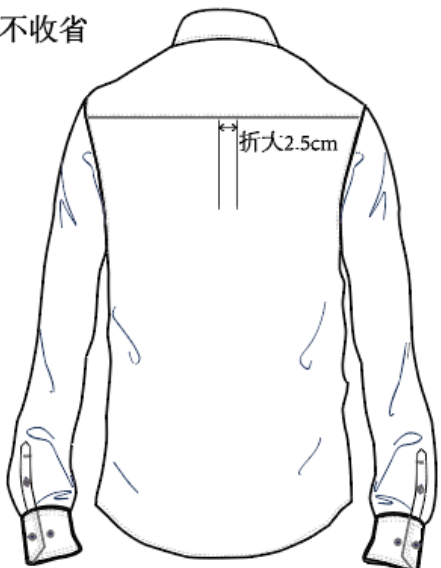

LZX-17-04

修身款: 01与02款

合身、宽松款: 03与04款



# 03: 男装衬衫缝制工艺

(6) 过肩裁剪方式、袖祺、袖祥、礼服拼贴工艺设计

## 过肩裁剪方式

过肩裁剪方式:

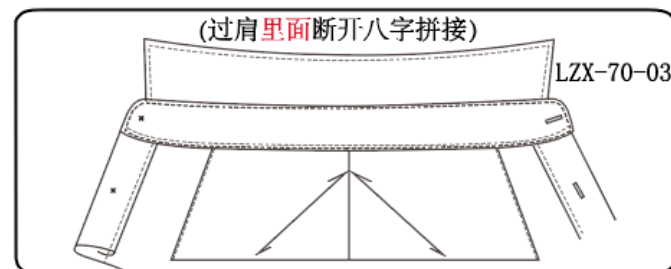
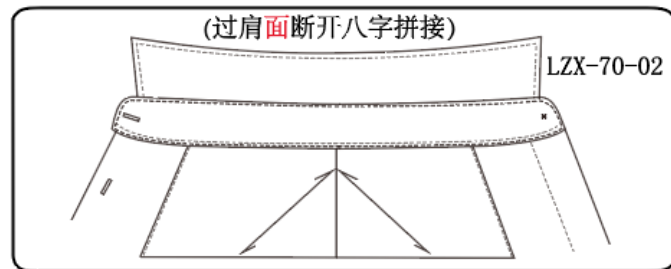
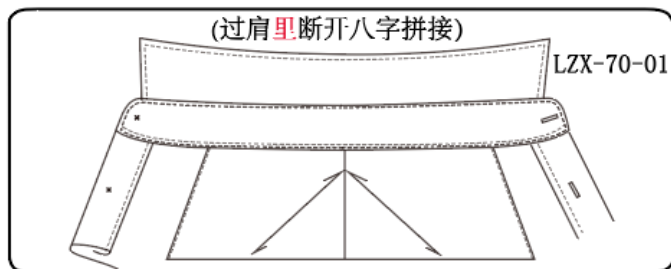
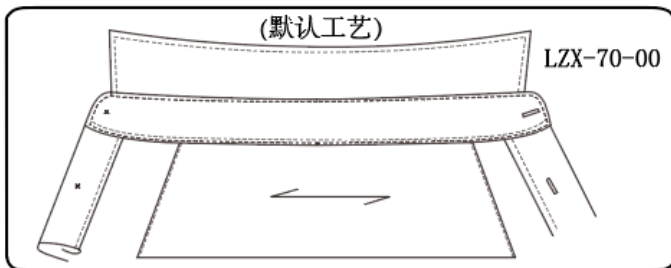

# 03: 男装衬衫缝制工艺

(6) 过肩裁剪方式、袖祺、袖袷、礼服拼贴工艺设计

## 袖祺工艺



LZX-60-01 ( 剑型袖祺 ) ( 默认袖祺 )

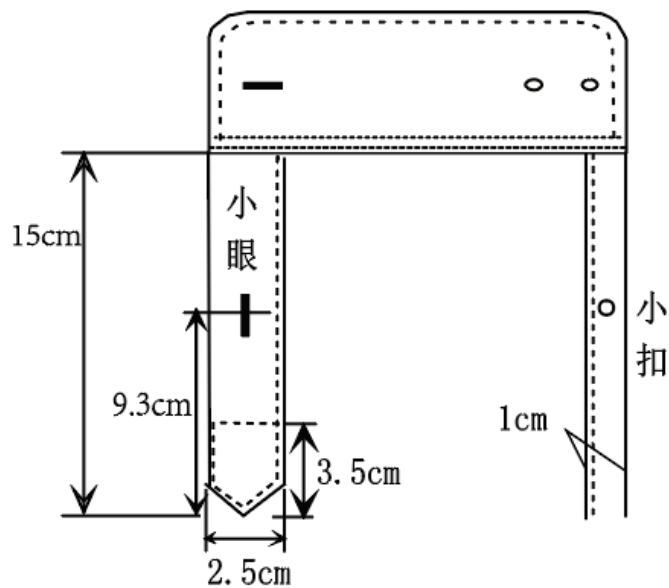

LZX-60-02 ( 直角袖祺 )

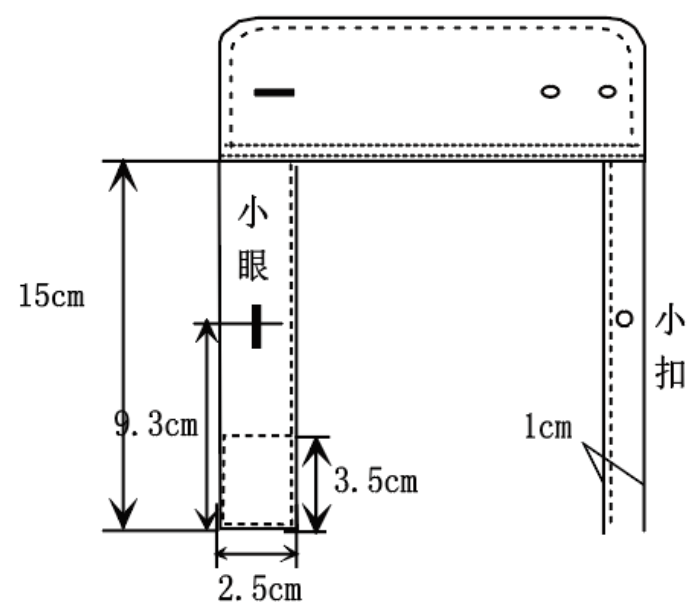

# 03: 男装衬衫缝制工艺

## (6) 过肩裁剪方式、袖袢、礼服拼贴工艺设计

### 袖袢

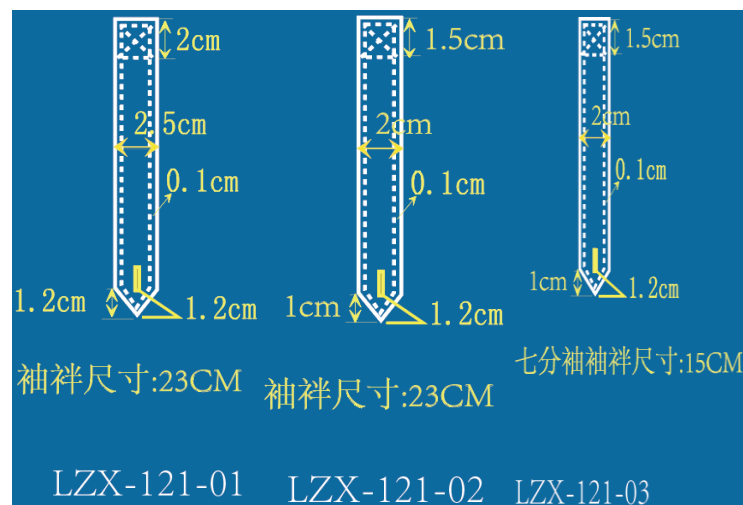
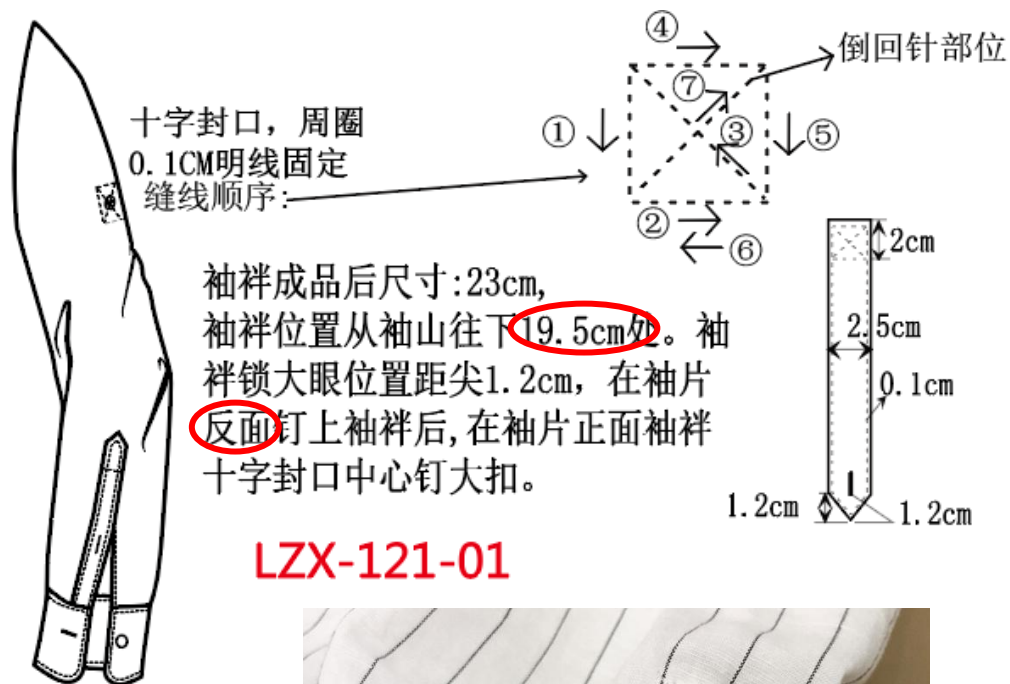

01与02区别: 袖袢宽窄不同

# 03: 男装衬衫缝制工艺

## (6) 过肩裁剪方式、袖袂、礼服拼贴工艺设计

### 礼服拼贴工艺

[1987定制礼服衬衫照片](#)

礼服拼贴款一和三  
LZX-20-01、03  
对应门襟：编号6或7  
拼贴面料：管状面料

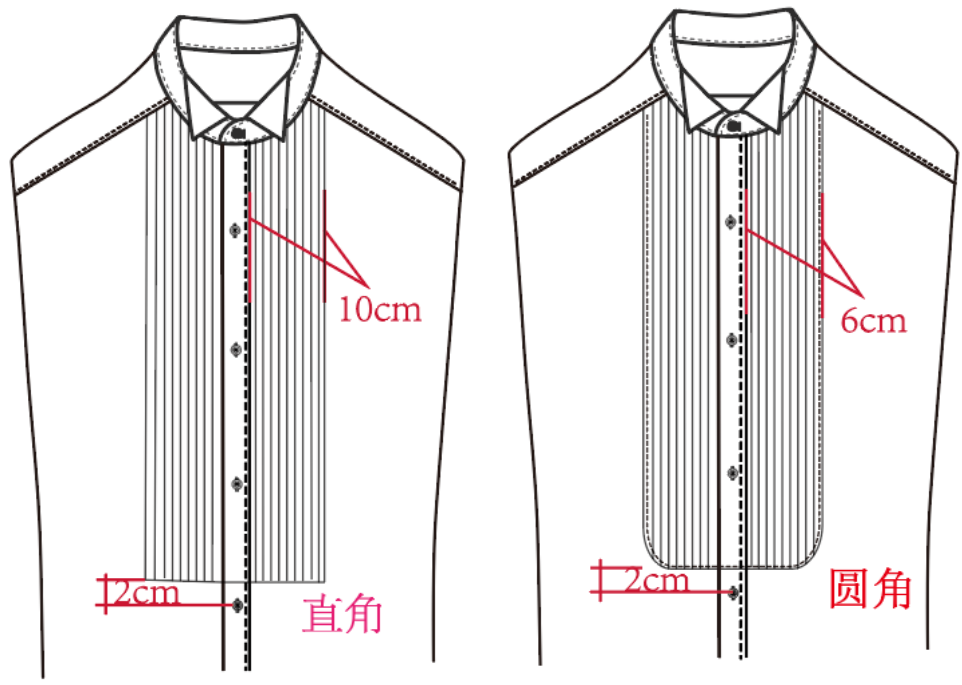

# 03: 男装衬衫缝制工艺

## (6) 过肩裁剪方式、袖袷、礼服拼贴工艺设计

### 礼服拼贴工艺

礼服拼贴款二、四  
LZX-20-02、04  
LZX-20-02对应门襟：编号4  
LZX-20-04对应门襟：编号6或7  
拼贴面料：管状面料

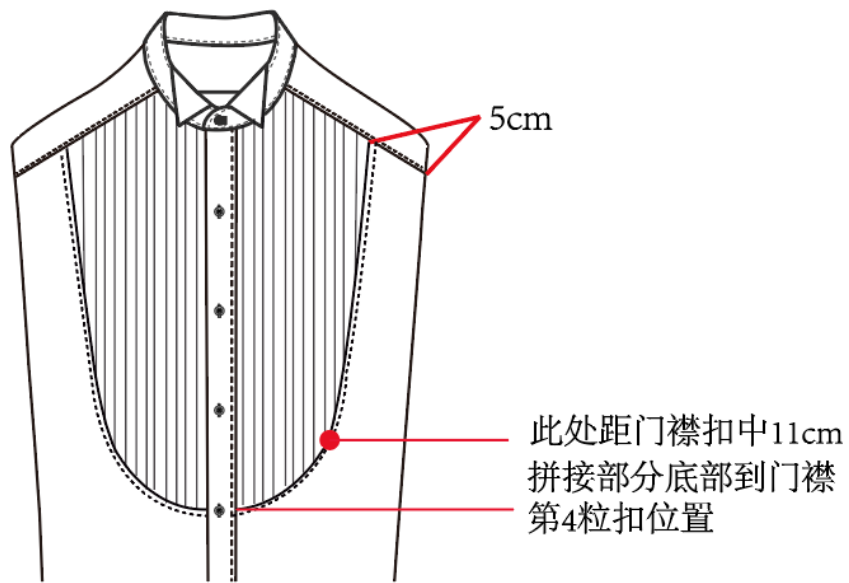
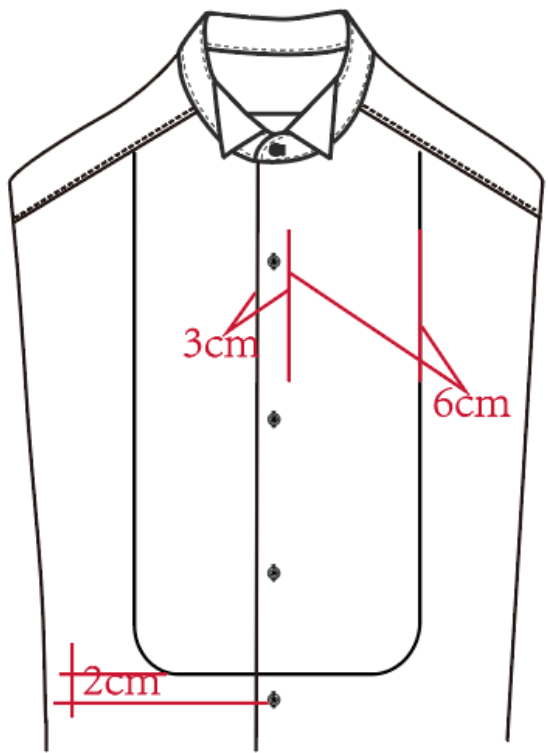

# 03: 男装衬衫缝制工艺

## (8) 织带、配色工艺

### 织带



织带宽度:  
0.2-0.3CM  
1CM  
1.2\1.3/1.4/1.6/1.7

# 03: 男装衬衫缝制工艺

## (8) 织带、配色工艺

### 织带

必须是外贴袖口

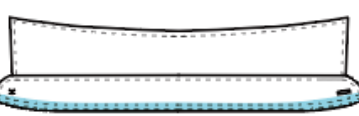
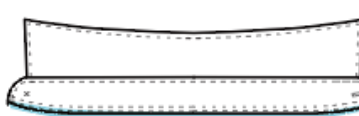
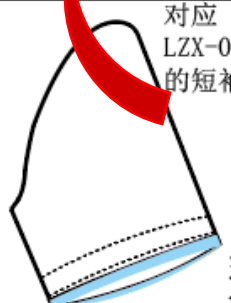
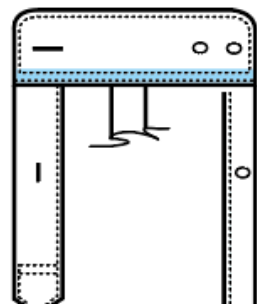
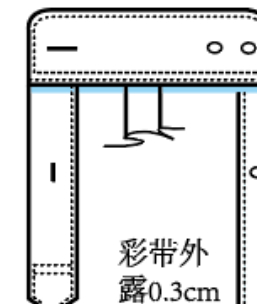
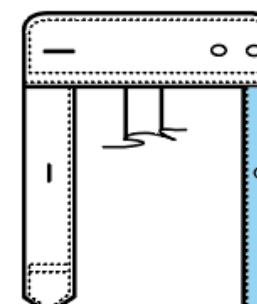
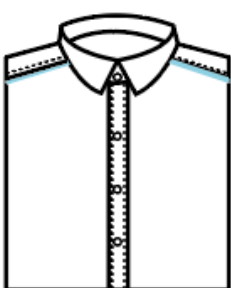
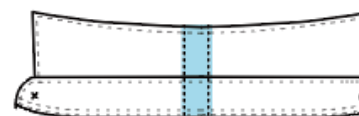
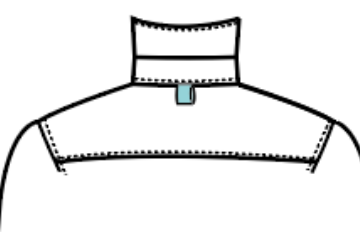
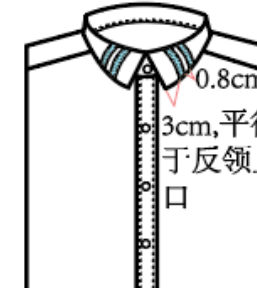
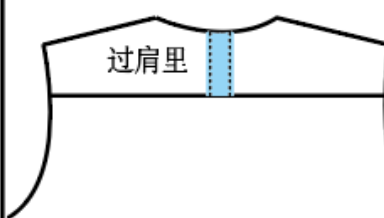
|                                                                                                    |                                                                                                    |                                                                                                                            |                                                                                                                    |                                                                                                      |                                                                                     |
|----------------------------------------------------------------------------------------------------|----------------------------------------------------------------------------------------------------|----------------------------------------------------------------------------------------------------------------------------|--------------------------------------------------------------------------------------------------------------------|------------------------------------------------------------------------------------------------------|-------------------------------------------------------------------------------------|
|                    |  <p>彩带外露0.3cm</p> |  <p>对应LZX-02-53的短袖口做法。<br/>彩带外露0.3cm</p> |                                 |  <p>彩带外露0.3cm</p> |  |
| <p>LZX-81-01<br/>底领面下止口贴彩带</p>                                                                     | <p>LZX-81-02<br/>底领面下止口夹彩带</p>                                                                     | <p>LZX-81-03<br/>短袖口外止口夹彩带</p>                                                                                             | <p>LZX-81-04<br/>绉袖头贴彩带</p>                                                                                        | <p>LZX-81-05<br/>绉袖头夹彩带</p>                                                                          | <p>LZX-81-06<br/>小袖祺贴彩带</p>                                                         |
|  <p>彩带外露0.3cm</p> |                  |                                         |  <p>0.8cm<br/>3cm, 平行于反领止口</p> |  <p>过肩里</p>      |                                                                                     |
| <p>LZX-81-07<br/>肩缝处夹彩带</p>                                                                        | <p>LZX-81-08<br/>底领面反领面贴彩带</p>                                                                     | <p>LZX-81-09<br/>后领窝中心对折夹彩带</p>                                                                                            | <p>LZX-81-10<br/>反领面前端贴彩带</p>                                                                                      | <p>LZX-81-11<br/>过肩里中心竖向贴彩带</p>                                                                      |                                                                                     |

### 织带

底领下止口贴织带





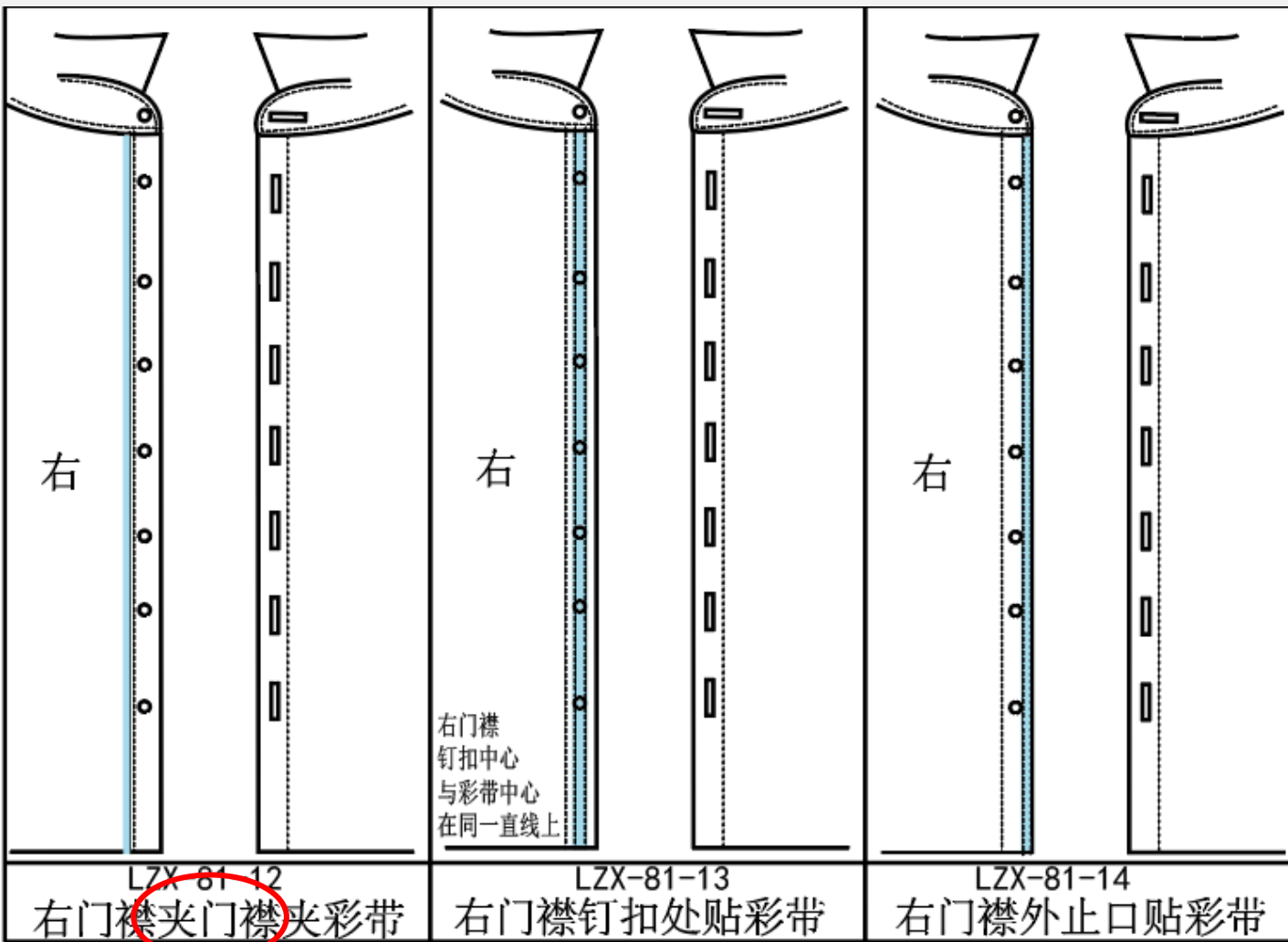





### 织带

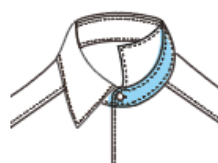
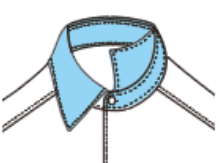
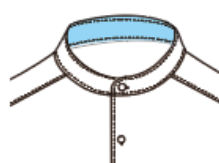

# 03: 男装衬衫缝制工艺

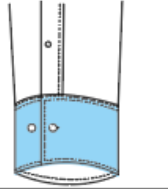
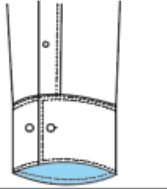
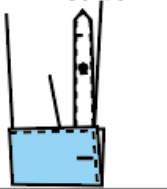
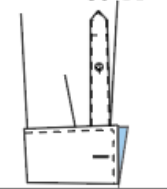
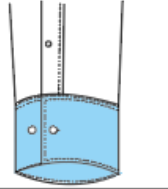
## (8) 织带、配色工艺

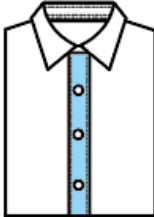
### 配色部位

|       |                                                                                                  |                                                                                                   |                                                                                                  |                                                                                                  |                                                                                                  |                                                                                                  |                                                                                                  |
|-------|--------------------------------------------------------------------------------------------------|---------------------------------------------------------------------------------------------------|--------------------------------------------------------------------------------------------------|--------------------------------------------------------------------------------------------------|--------------------------------------------------------------------------------------------------|--------------------------------------------------------------------------------------------------|--------------------------------------------------------------------------------------------------|
| 领子配色  | LZX-80-01<br>   | LZX-80-02<br>    | LZX-80-03<br> | LZX-80-04<br> | LZX-80-05<br> | LZX-80-06<br> | LZX-80-07<br> |
|       | 反领面配色                                                                                            | 反领里配色                                                                                             | 底领面配色                                                                                            | 底领里配色                                                                                            | 整个领子全配色                                                                                          | 立领里配色                                                                                            | 立领面配色                                                                                            |
| 袖头配色  | LZX-80-08<br>   | LZX-80-09<br>   | LZX-80-10<br> | LZX-80-11<br> | LZX-80-12<br> |                                                                                                  |                                                                                                  |
|       | 袖头面配色                                                                                            | 袖头里配色                                                                                             | 礼服袖头面配色                                                                                          | 礼服袖头里配色                                                                                          | 整个袖头全配色                                                                                          |                                                                                                  |                                                                                                  |
| 短袖口配色 | LZX-80-13<br>  | LZX-80-14<br>   |                                                                                                  |                                                                                                  |                                                                                                  |                                                                                                  |                                                                                                  |
|       | 短袖口面贴布配色                                                                                         | 短袖口里贴布配色                                                                                          |                                                                                                  |                                                                                                  |                                                                                                  |                                                                                                  |                                                                                                  |
| 门襟配色  | LZX-80-15<br> | LZX-80-16<br> |                                                                                                  |                                                                                                  |                                                                                                  |                                                                                                  |                                                                                                  |
|       | 左门襟贴门襟条配色                                                                                        | 右门襟夹门襟条配色                                                                                         |                                                                                                  |                                                                                                  |                                                                                                  |                                                                                                  |                                                                                                  |

# 03: 男装衬衫缝制工艺

## (8) 织带、配色工艺

### 配色部位

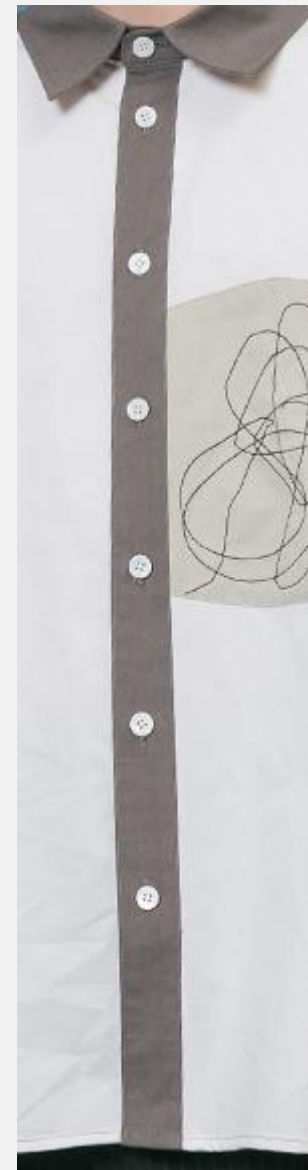
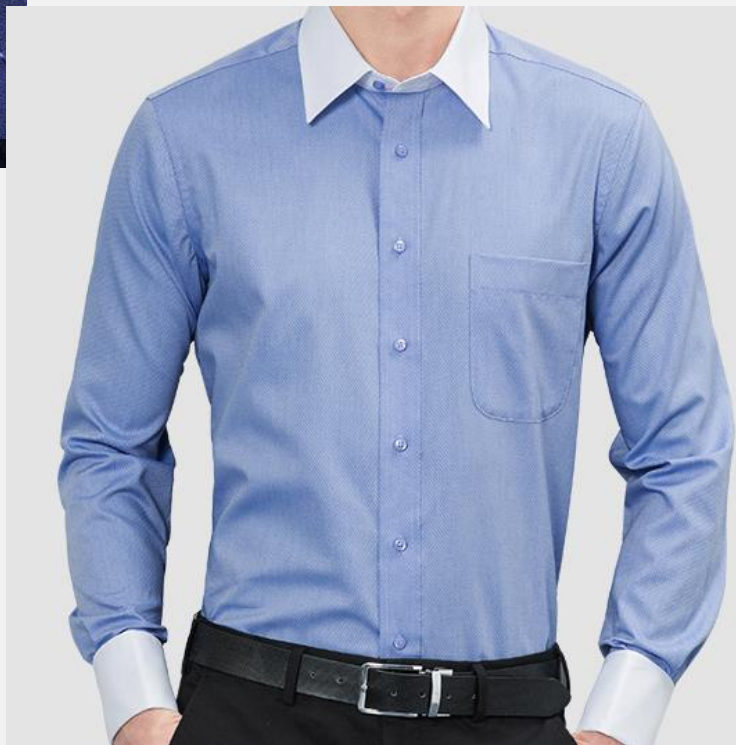

# 03: 男装衬衫缝制工艺

## (9) 主唛 (商标)、锁钉位置

### 商标位置

LZX-08-01 主唛位置1 (默认位置)

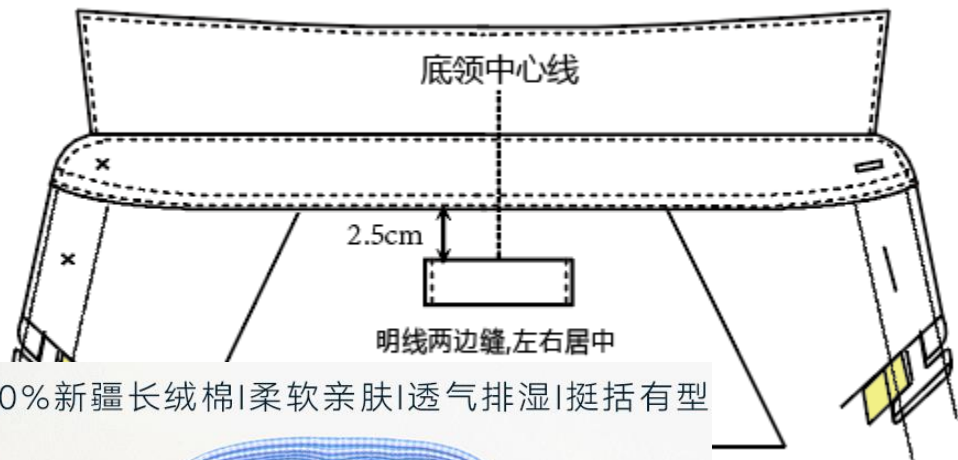

100%新疆长绒棉 | 柔软亲肤 | 透气排湿 | 挺括有型



LZX-08-02 主唛位置2 (男右/女左门襟)

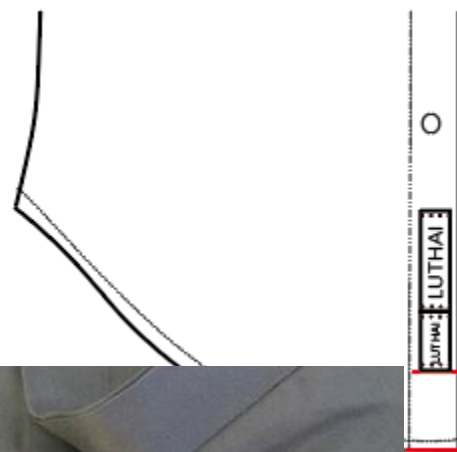

只有主唛钉在门襟时,  
主唛距底边5cm.

主唛和面料唛同时钉在门襟时,  
主唛在上, 两唛紧挨着,  
面料唛距底边5cm.

5cm



# 03：男装衬衫缝制工艺

(9) 主唛（商标）、锁钉位置

## 尺码唛位置

尺码位置补充说明：

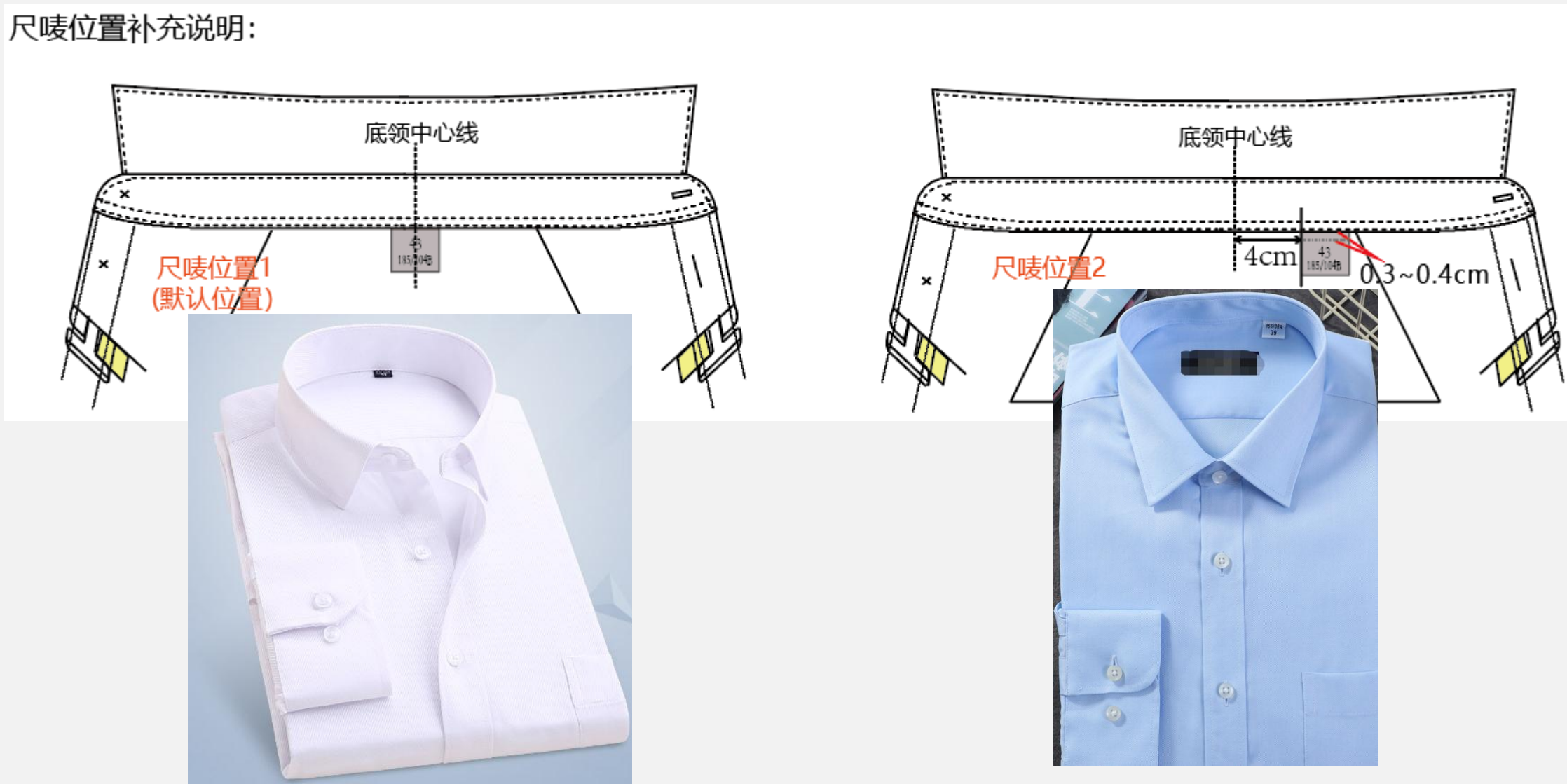

# 03: 男装衬衫缝制工艺

## (9) 主唛 (商标)、锁钉位置

### 锁钉位置

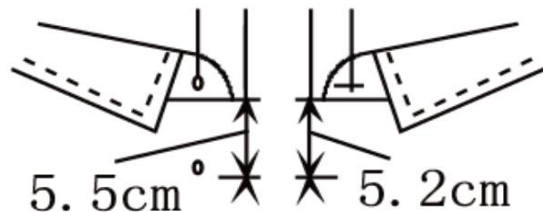
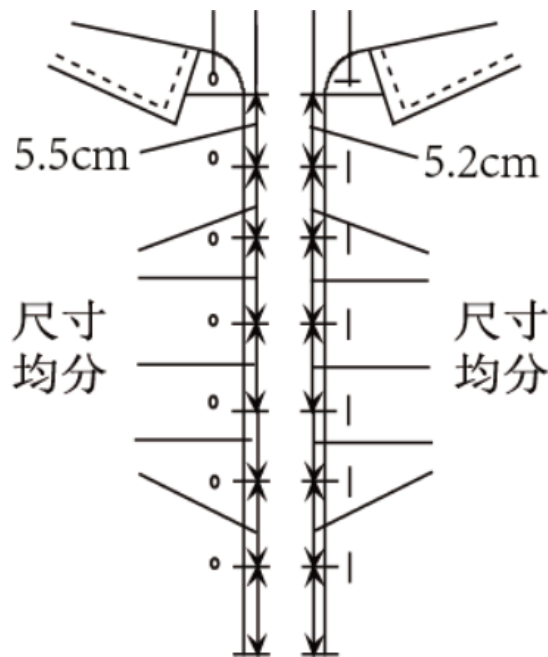

底领边距第一粒扣5.5cm  
LZX-90-02 (默认做法)

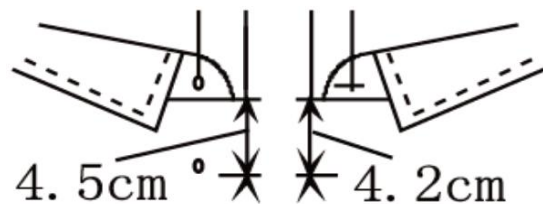

底领边距第一粒扣4.5cm  
LZX-90-01

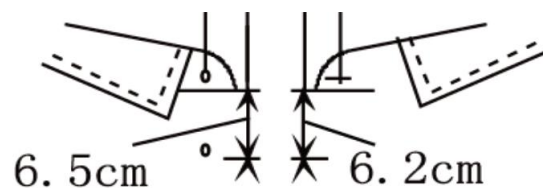

底领边距第一粒扣6.5cm  
LZX-90-03

| 门襟锁钉位置编号                            | 后衣长尺寸     | 门襟第一个眼位置     | 门襟扣眼数量 |
|-------------------------------------|-----------|--------------|--------|
| 默认锁钉位置<br>LZX<br> <br>90<br> <br>02 | 67CM-69CM | 距离底领下止口5.2CM | 6个     |
|                                     | 70CM-72CM | 距离底领下止口5.2CM | 6个     |
|                                     | 73CM-76CM | 距离底领下止口5.2CM | 6个     |
|                                     | 77CM-79CM | 距离底领下止口5.2CM | 7个     |
|                                     | 80CM-81CM | 距离底领下止口5.2CM | 7个     |
|                                     | 82CM-84CM | 距离底领下止口5.2CM | 7个     |
|                                     | 85CM以上    | 距离底领下止口5.2CM | 7个     |

| 门襟锁钉位置编号                  | 后衣长尺寸     | 门襟第一个眼位置     | 门襟扣眼数量 |
|---------------------------|-----------|--------------|--------|
| LZX<br> <br>90<br> <br>01 | 67CM-69CM | 距离底领下止口4.2CM | 6个     |
|                           | 70CM-72CM | 距离底领下止口4.2CM | 6个     |
|                           | 73CM-76CM | 距离底领下止口4.2CM | 6个     |
|                           | 77CM-80CM | 距离底领下止口4.2CM | 7个     |
|                           | 81CM-84CM | 距离底领下止口4.2CM | 7个     |
|                           | 85CM以上    | 距离底领下止口4.2CM | 7个     |

| 门襟锁钉位置编号                  | 后衣长尺寸     | 门襟第一个眼位置     | 门襟扣眼数量 |
|---------------------------|-----------|--------------|--------|
| LZX<br> <br>90<br> <br>03 | 67CM-69CM | 距离底领下止口6.2CM | 6个     |
|                           | 70CM-72CM | 距离底领下止口6.2CM | 6个     |
|                           | 73CM-75CM | 距离底领下止口6.2CM | 6个     |
|                           | 76CM-79CM | 距离底领下止口6.2CM | 7个     |
|                           | 80CM-81CM | 距离底领下止口6.2CM | 7个     |
|                           | 82CM-84CM | 距离底领下止口6.2CM | 7个     |
|                           | 85CM以上    | 距离底领下止口6.2CM | 7个     |

# 03: 男装衬衫缝制工艺

(9) 主唛 (商标)、锁钉位置

锁钉位置



场合需求、穿衣习惯



# 03: 男装衬衫缝制工艺

(10) 刺绣字体、图案、位置工艺

## 刺绣

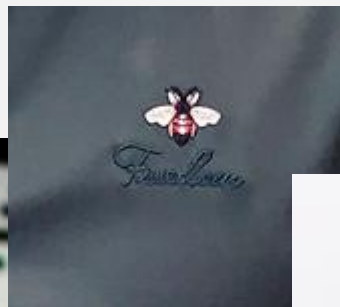
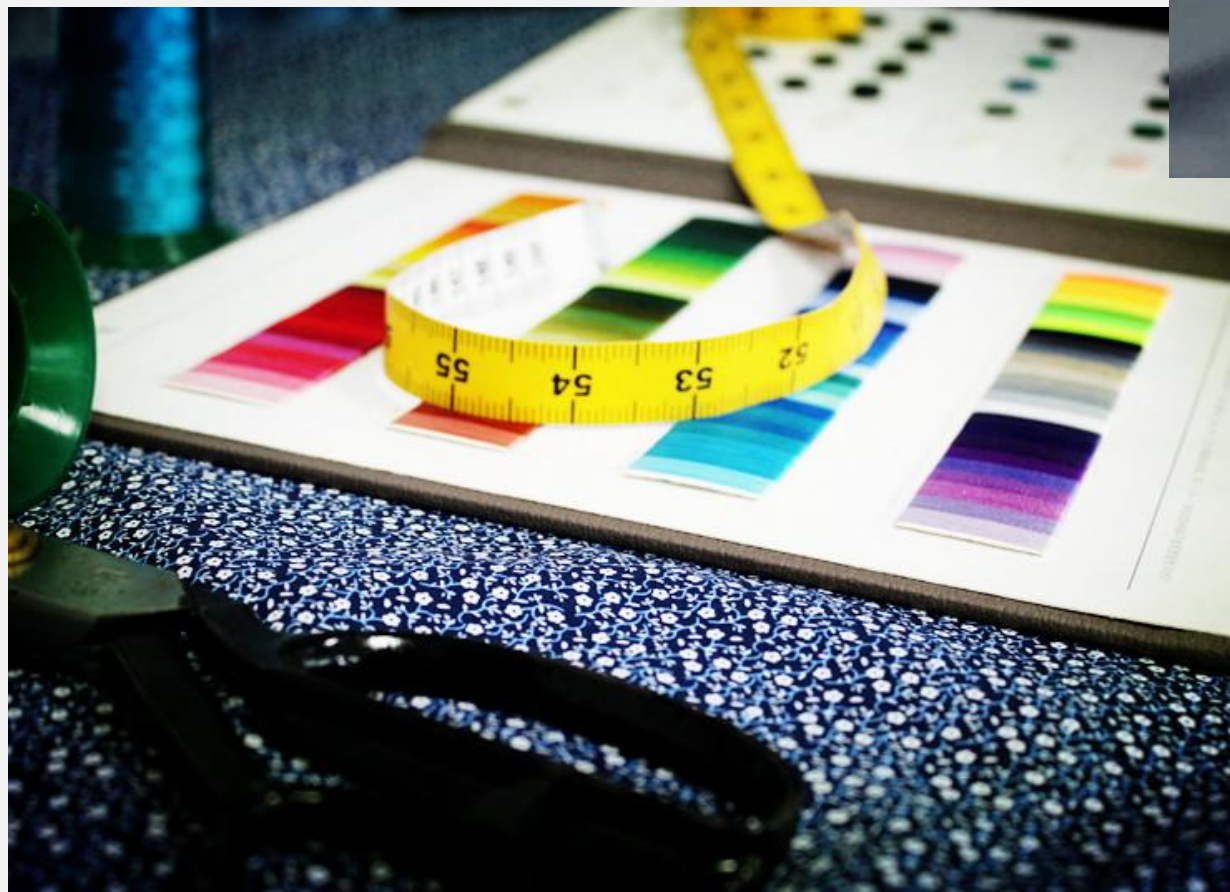

## 刺绣：22种字体

*abcdefghijklmnopqrstuvwxyz*

*ABCDEFGHIJKLMNOPQRSTUVWXYZ*

LZX-11-05

*abcdefghijklmnopqrstuvwxyz*

*ABCDEFGHIJKLMNOPQRSTUVWXYZ*

LZX-11-06

*abcdefghijklmnopqrstuvwxyz*

*ABCDEFGHIJKLMNOPQRSTUVWXYZ*

LZX-11-08

*abcdefghijklmnopqrstuvwxyz*

*ABCDEFGHIJKLMNOPQRSTUVWXYZ*

LZX-11-16

面面俱到 定制更好

LZX-11-17

面面俱到 定制更好

LZX-11-18

# 03: 男装衬衫缝制工艺

(10) 刺绣字体、图案、位置工艺

刺绣：24种生肖、24种星座、十二地支12、定制爱5、数字10

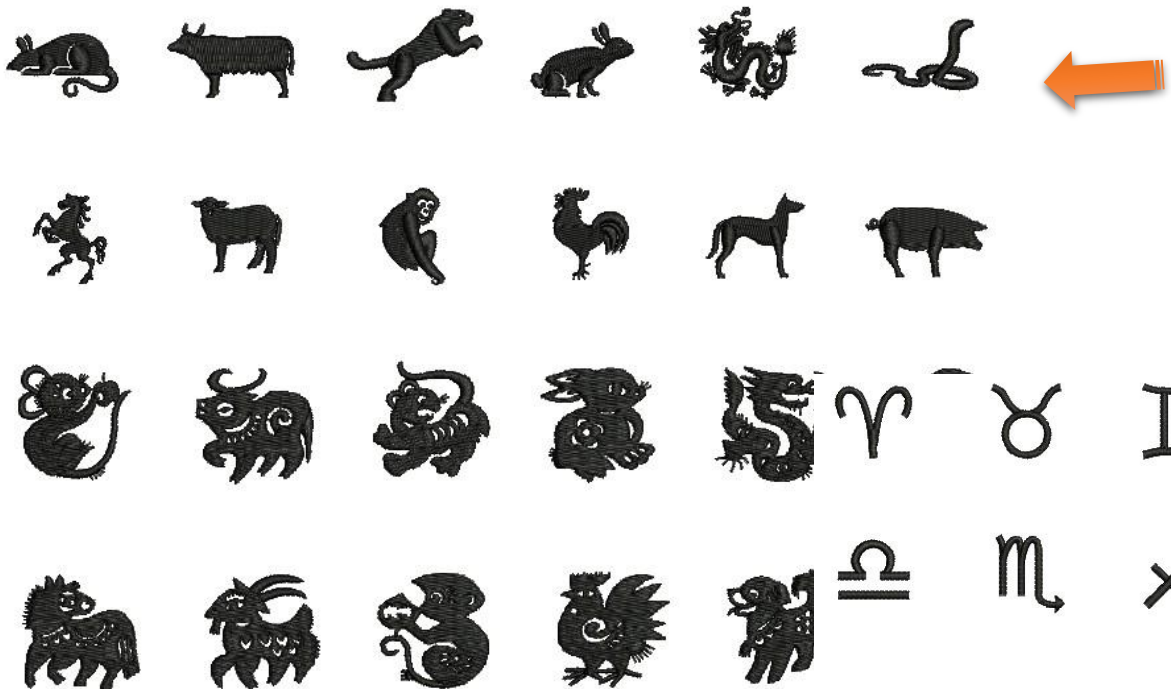

LZX-11-23

1.2.4.6.8.11.12最低高度1.5CM  
3.5.7.9.10最低高度2CM

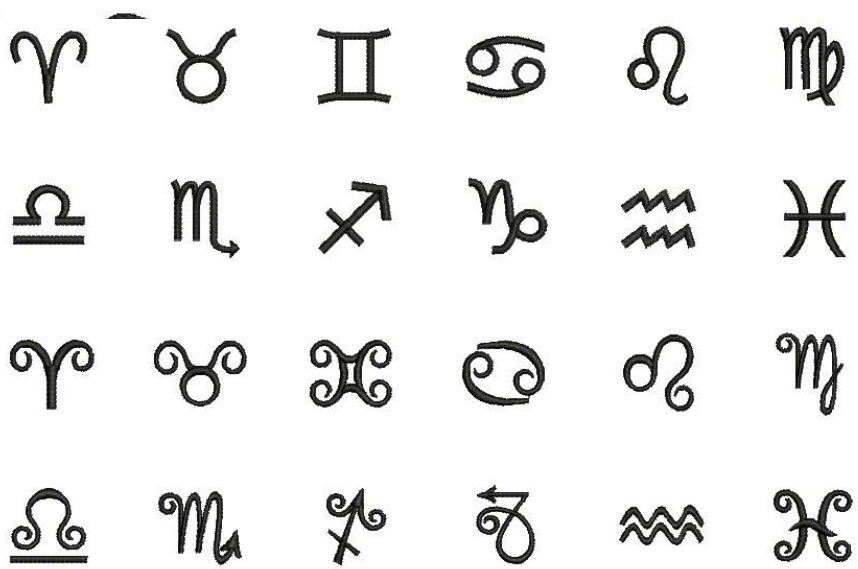

LZX-11-24

子 丑 寅 卯 辰 巳  
午 未 申 酉 戌 亥

LZX-11-25

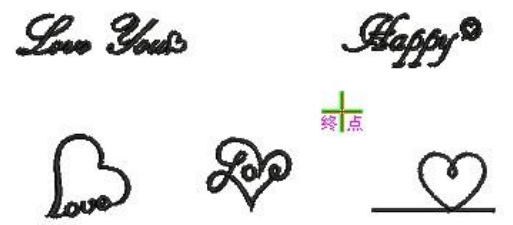

LZX-11-26

1 2 3 4 5 6 7 8 9 0

LZX-11-27

最低高度1CM

# 03: 男装衬衫缝制工艺

## (10) 刺绣字体、图案、位置工艺

边距起点1.5CM, 握边2.5CM

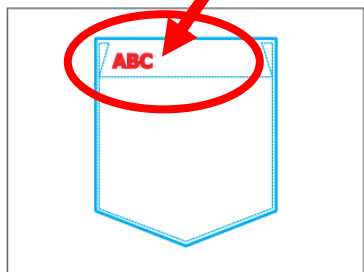

LZX-13-01  
袋口

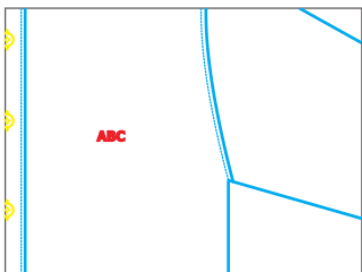

LZX-13-02  
左胸

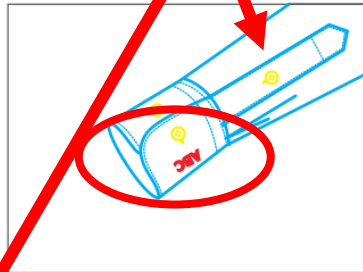

LZX-13-07  
右袖头侧

握边明线+明线宽=1.6CM

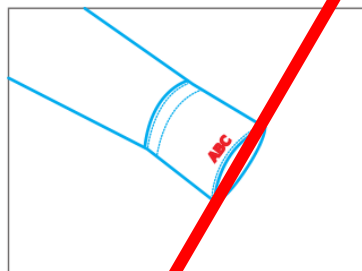

LZX-13-04  
左袖头外

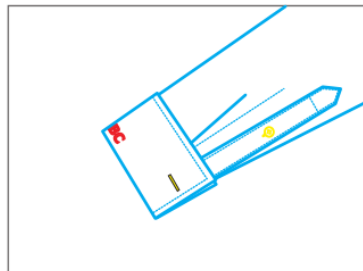

LZX-13-09  
礼服右袖口中

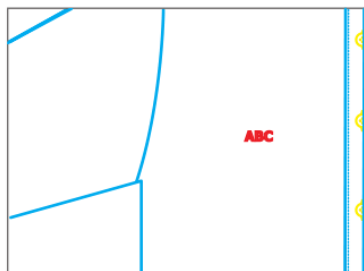

LZX-13-03  
右胸

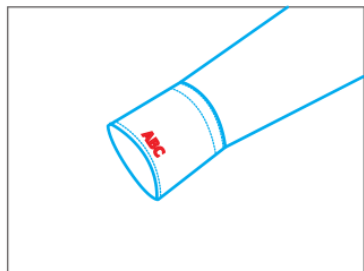

LZX-13-05  
右袖头外

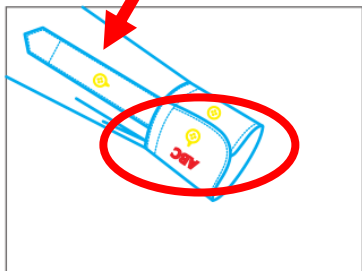

LZX-13-06  
左袖头侧

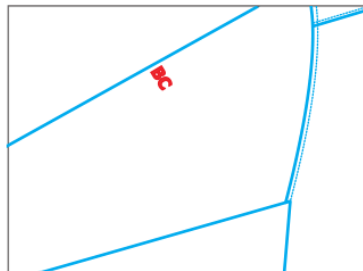

LZX-13-11  
右袖中

袖口宽2.5CM-1CM内

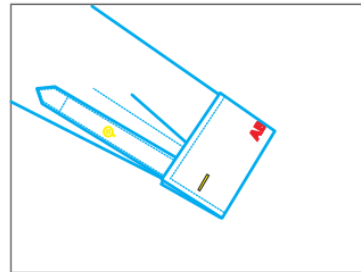

LZX-13-08  
礼服左袖口中

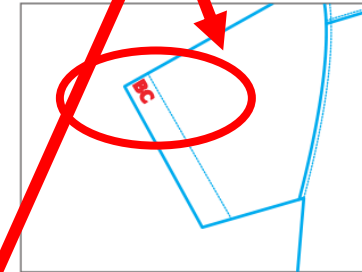

LZX-13-13  
右短袖中



LZX-13-10  
左袖中

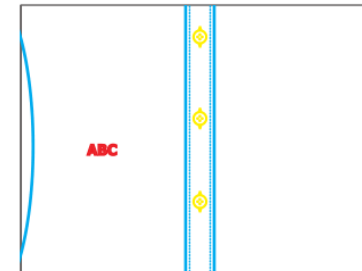

LZX-13-15  
右大身

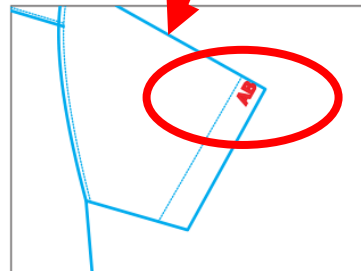

LZX-13-12  
左短袖中

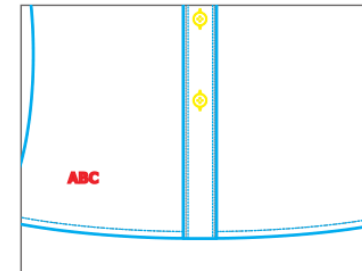

LZX-13-17  
右下摆

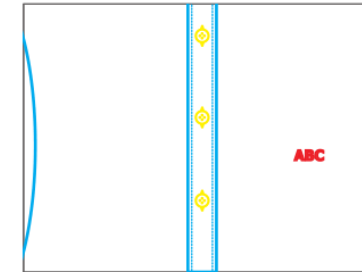

LZX-13-14  
左大身

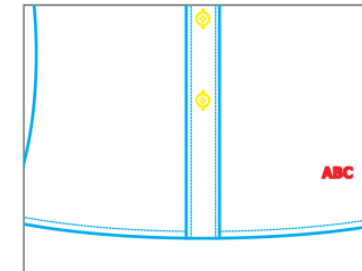

LZX-13-16  
左下摆

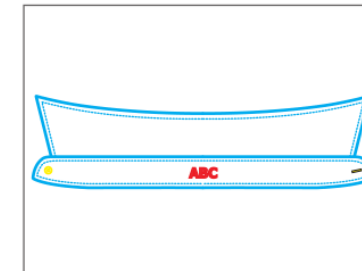

LZX-13-18  
底领里中

# 03: 男装衬衫缝制工艺

## (10) 刺绣字体、图案、位置工艺

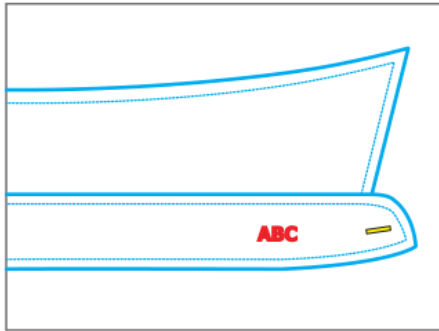

LZX-13-19  
底领面左

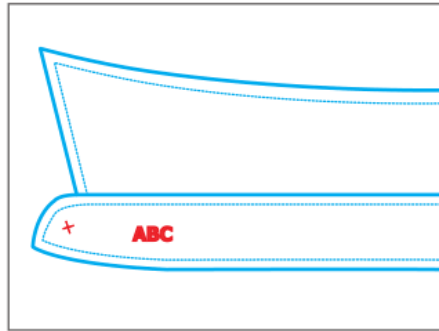

LZX-13-20  
底领面右

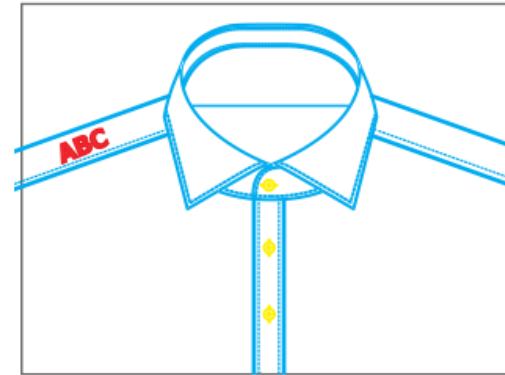

LZX-13-25  
右过肩面中



LZX-13-26  
后过肩面中

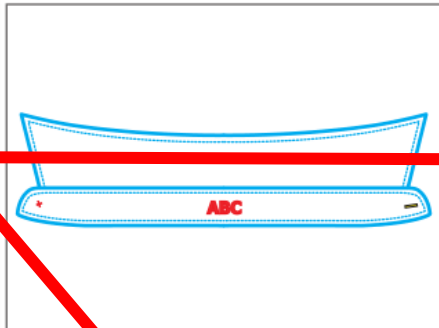

LZX-13-21  
底领面中

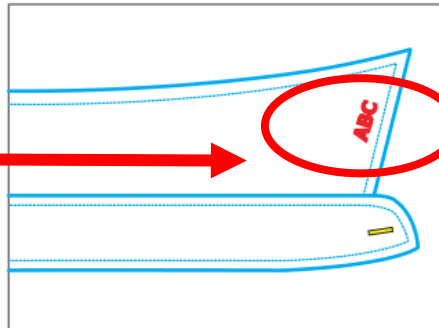

LZX-13-22  
翻领面左

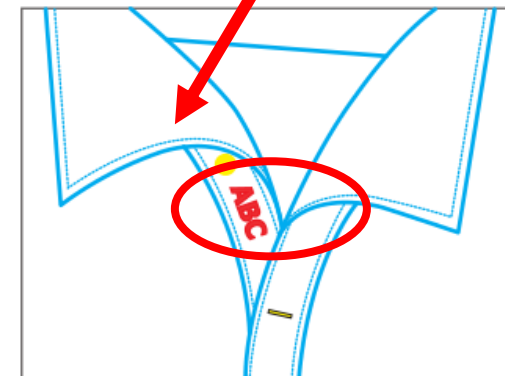

LZX-13-27  
右门襟上

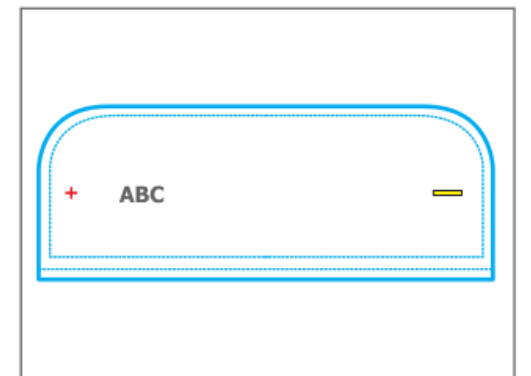

LZX-13-28  
左袖里

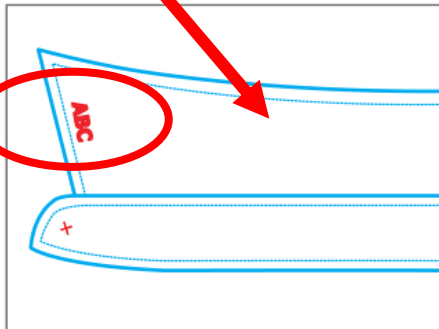

LZX-13-23  
翻领面右

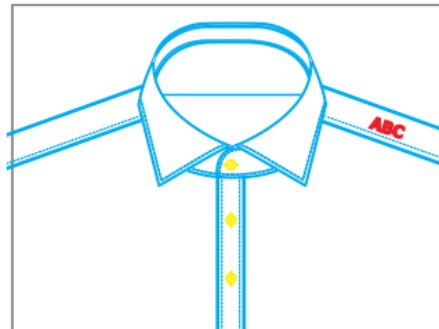

LZX-13-24  
左过肩面中

见下一页图片

距边1CM  
领尖长-明线宽居中  
两边各留0.5CM

领尖锁眼的:  
领尖进2.5CM  
领止口留0.5CM

领尖长小于5CM的  
不能选择此位置

### 03：男装衬衫缝制工艺

(10) 刺绣字体、图案、位置工艺

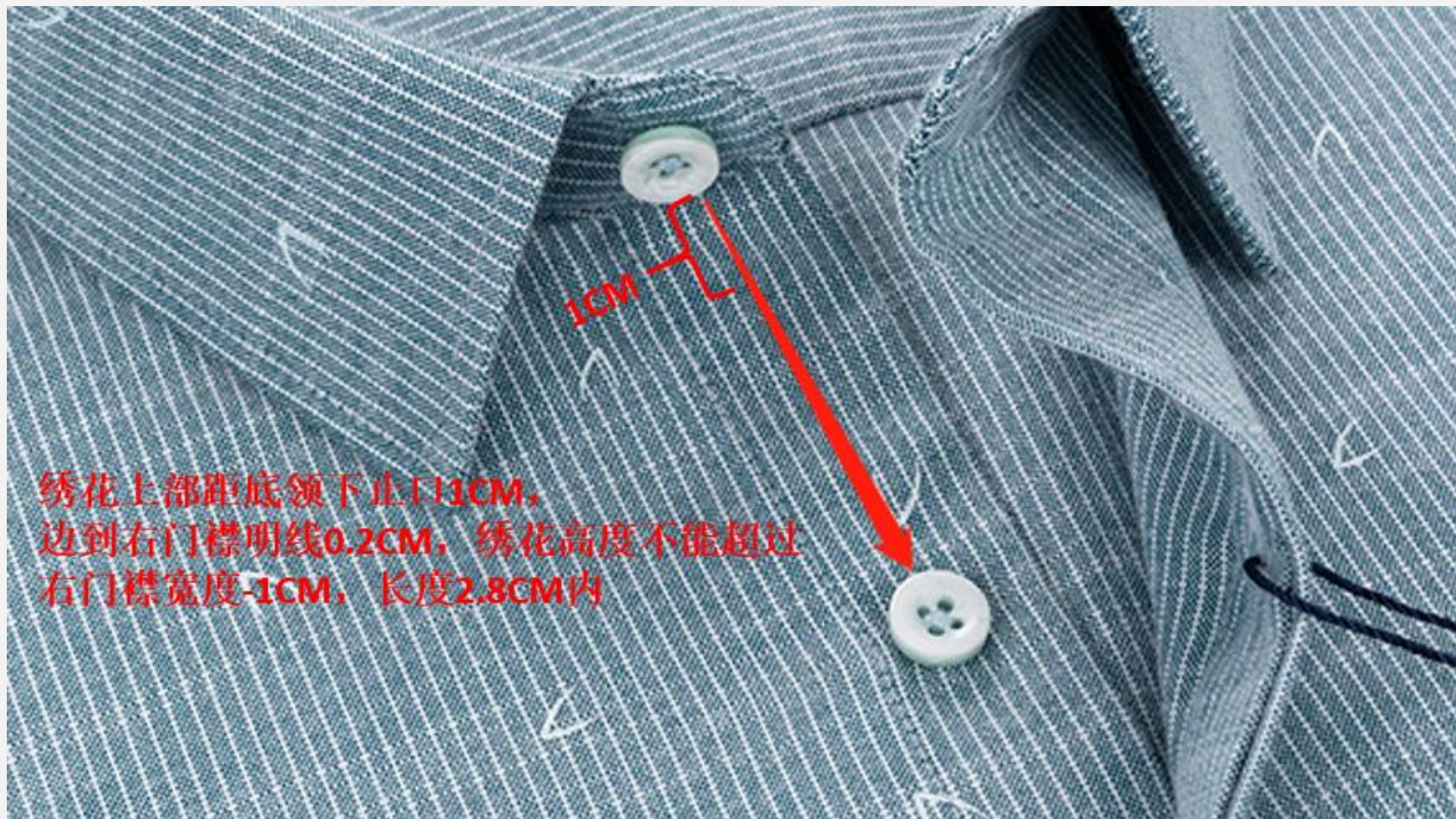

# 03: 男装衬衫缝制工艺

(10) 刺绣字体、图案、位置工艺

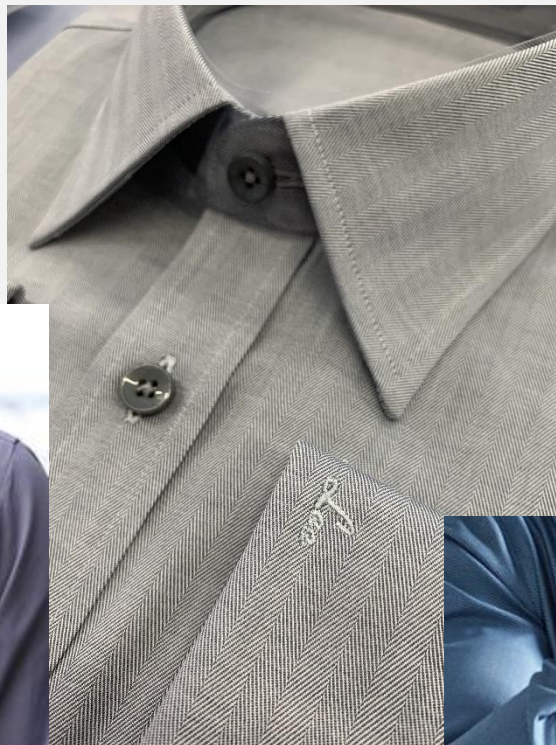

# 03: 男装衬衫缝制工艺

## (11) 免烫级别、嵌条部位

| 编号     |    | 4.1(全身加) | 4.2 |
|--------|----|----------|-----|
| 嵌条使用部位 | 口袋 | √        |     |
|        | 肩缝 | √        |     |
|        | 过肩 | √        | √   |
|        | 袖笼 | √        | √   |
|        | 侧缝 | √        | √   |
|        | 袖祺 | √        |     |



# 03: 男装衬衫缝制工艺

(11) 免烫级别、嵌条部位



DP免烫

非DP免烫



# 03: 男装衬衫缝制工艺

(11) 免烫级别、嵌条部位

## 2. 潮交联

摊缝→烧毛→退浆→丝光→液氨→预柔软→轧树脂→堆置→水洗→拉幅定型→预缩

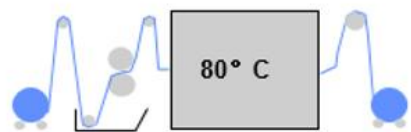

1 上料  
烘干布面含潮率6~7%，



2 转动 贮存反应  
20-24 小时  
35 ° C



树脂呈强酸性，先加碱，中和。再加醋酸，使其成弱酸性。

3 水洗  
中和

4 整理

液氨潮交联：加入抗皱助剂后，在30-35°C的恒温室堆置24小时，然后焙烘，面料平整度可达到3.5-4.0级，耐水洗50次以上，可称为永久免烫

## 4. 成衣免烫

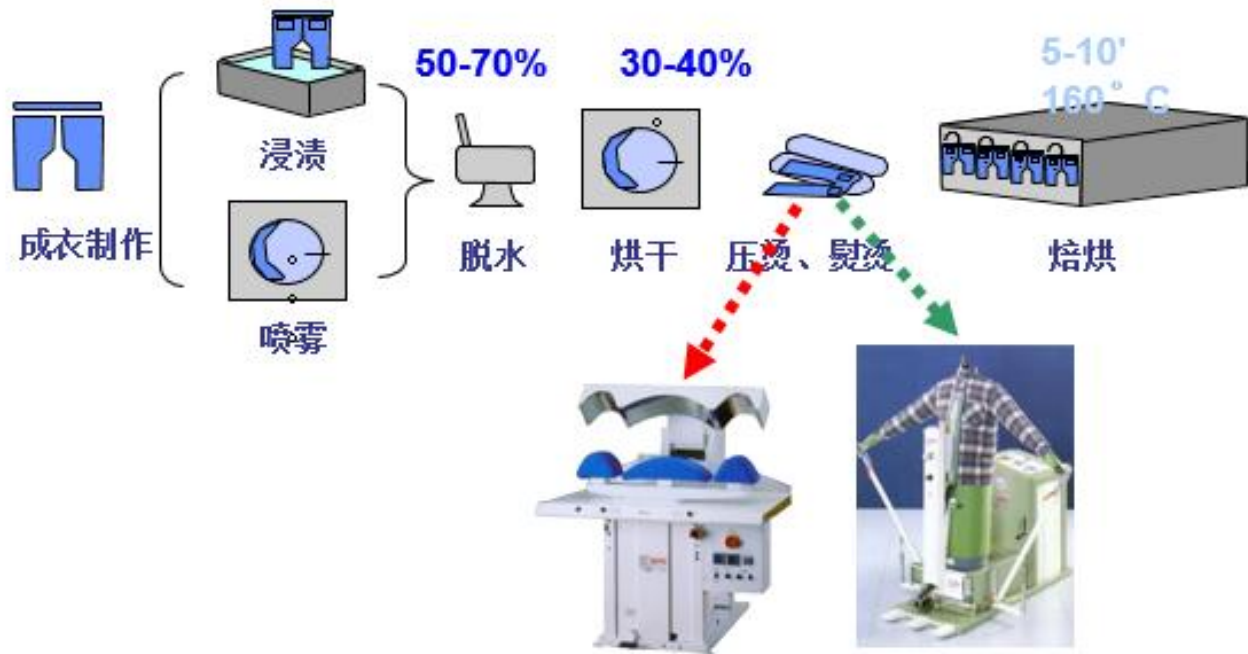

成衣免烫：俗称DP，面料本身没有抗皱性，按正常工艺缝制结束，然后加助剂、焙烘、水洗，此时的成衣才会具有抗皱性，平整度可达3.5级以上。

# 03：男装衬衫缝制工艺

(11) 免烫级别、嵌条部位

有嵌条与无嵌条区别



# 03：男装衬衫缝制工艺

(11) 免烫级别、嵌条部位

有嵌条与无嵌条区别



# 03：男装衬衫缝制工艺

(11) 免烫级别、嵌条部位

有嵌条与无嵌条区别



# 03：男装衬衫缝制工艺

(11) 免烫级别、嵌条部位

有嵌条与无嵌条区别



## 03：男装衬衫缝制工艺

(11) 免烫级别、嵌条部位

有嵌条与无嵌条区别

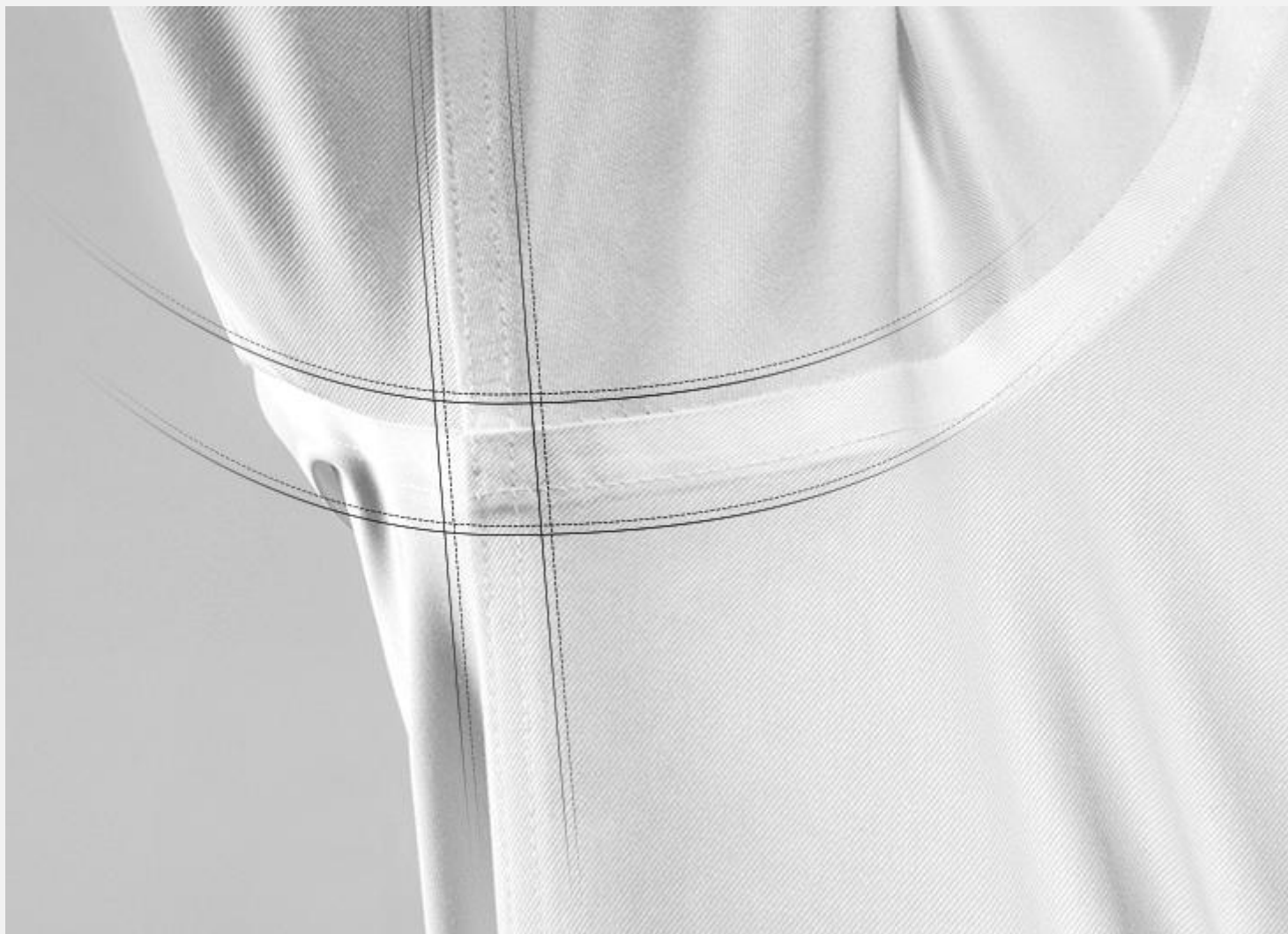

# 03: 男装衬衫缝制工艺

(12) 辅料 (纽扣、缝线、绣花线)

纽扣

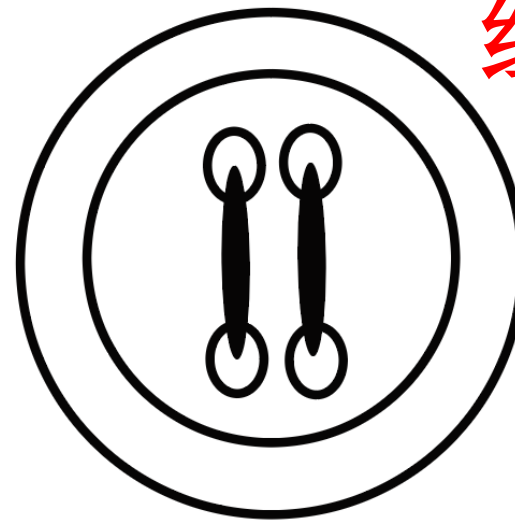
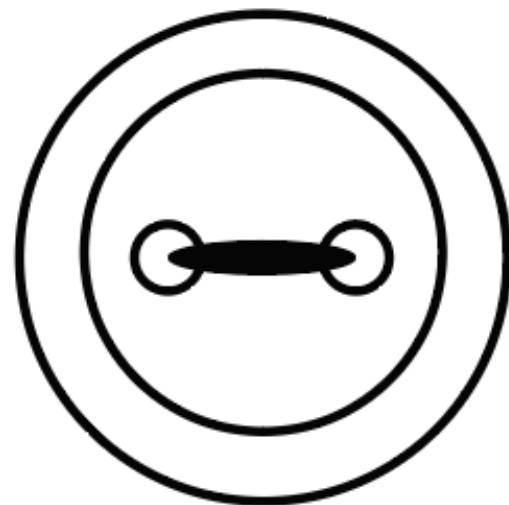
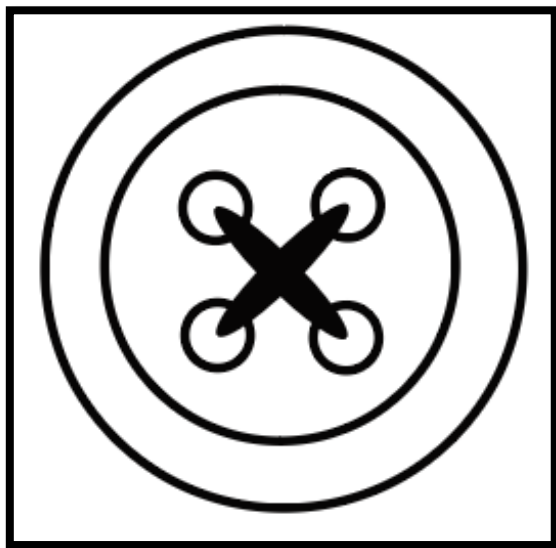

默认：十字钉扣，每眼不少于8根线

## 03：男装衬衫缝制工艺

(12) 辅料 (纽扣、缝线、绣花线)



辅料册内包含**91**种纽扣

# 03: 男装衬衫缝制工艺

## (12) 辅料 (纽扣、缝线、绣花线)



树脂扣系列: 30种



深海贝壳扣系列: KC12种+KH6种



珍珠贝壳扣系列: 15种



白蝶贝扣系列: 3种

# 03: 男装衬衫缝制工艺

(12) 辅料 (纽扣、缝线、绣花线)



陶瓷系列: 10种



金属钻系列: 10种



天然玉石系列: 5种

需要手工钉扣



# 03: 男装衬衫缝制工艺

(12) 辅料 (纽扣、缝线、绣花线)

## 缝线

### 高科技包芯线技术

高士DUAL DUTY是一种高品质的包芯线，其线芯用高韧度聚酯长丝制造，外面再包覆棉纤维。长丝线芯提供较高的强力及耐用度，而外部的长纤维棉花则可提供较佳的车缝效果。



COATS  
英国高士纱线

250年纱线制作工艺传承

高士是颜色专家

高士拥有全球性线品工艺和染色技术，种类、色彩丰富。

强韧性好  
不易断线  
光泽度高

## 绣花线



high and suit

# 04

## 女装衬衫缝制工艺

- (1) 衬衫各部位名称
- (2) 领型工艺设计
- (3) 袖口工艺设计
- (4) 前片工艺设计
- (5) 袖褶、袖祺工艺设计
- (6) 主唛（商标）、锁钉位置

# 04: 女装衬衫缝制工艺

(1) 衬衫各部位名称

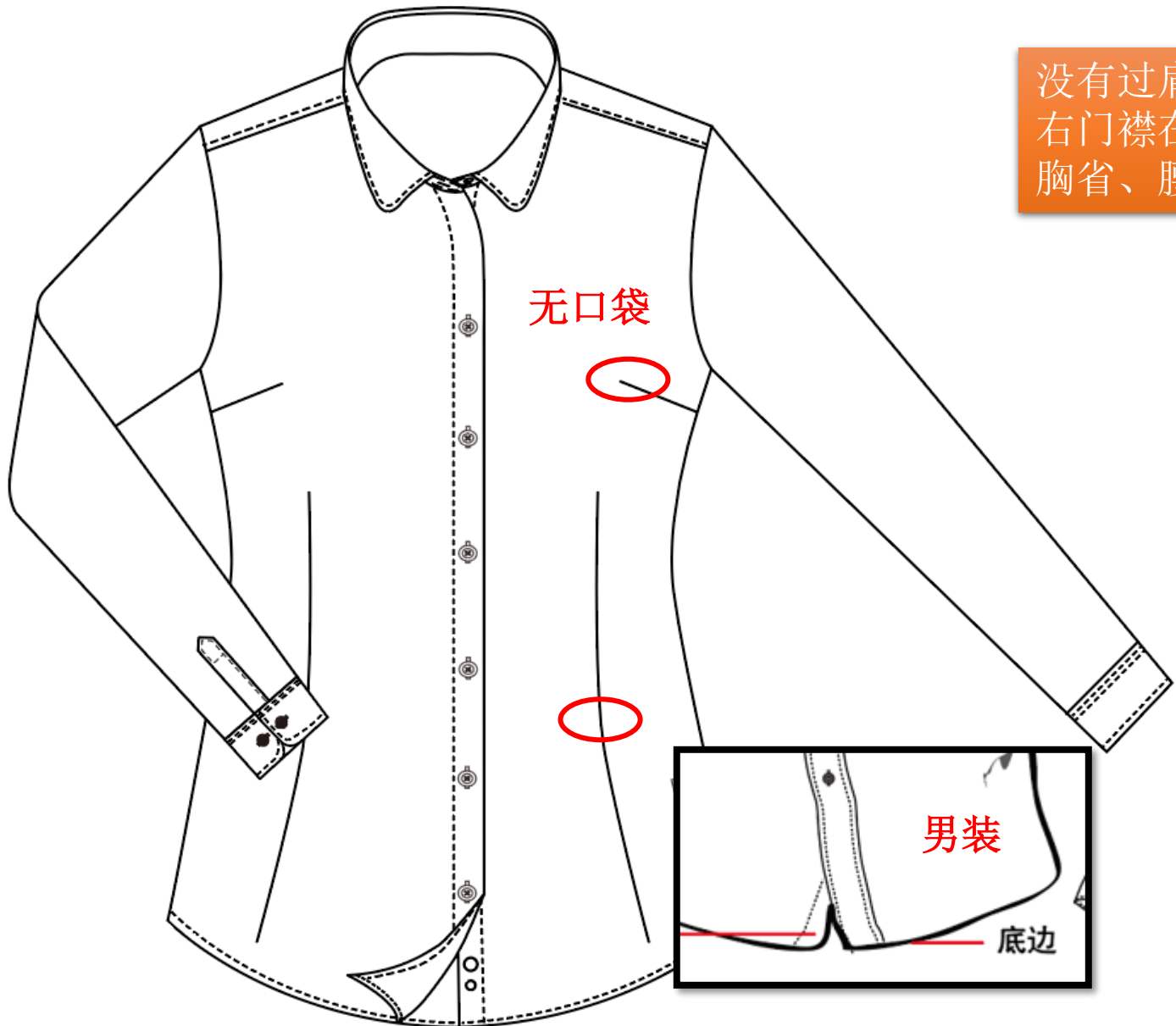

## 04: 女装衬衫缝制工艺

### (1) 衬衫各部位名称



# 04: 女装衬衫缝制工艺

## (1) 衬衫各部位名称



右门襟

五线合肩缝0.1cm明线

五线上袖无明线



五线合身无明线

后腰省倒向中心

- 1) 整件衬衫有大小扣两种扣型的, 备用扣1大1小钉下层门襟正面, 大在上, 距底6cm, 扣间距2cm; 整件衬衫有一种扣型的, 只钉这种扣型的1个备用扣, 距底6cm;
- 2) 下层门襟有唛的(如面料标), 距底4cm, 扣间距2cm。

洗唛钉左侧缝, 距底7cm, 洗唛显示成分, 对折使用, 二维码面朝上。

底边加衬, 明线0.5cm

女装: 明线宽0.1CM

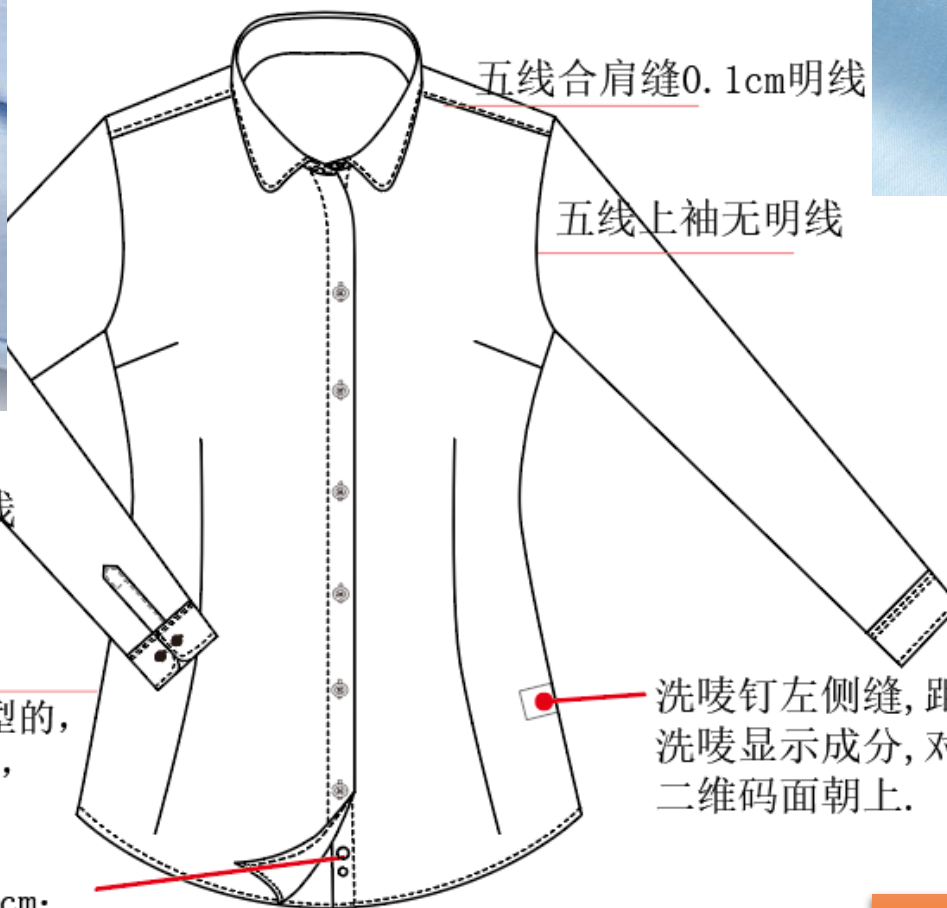

### 领型

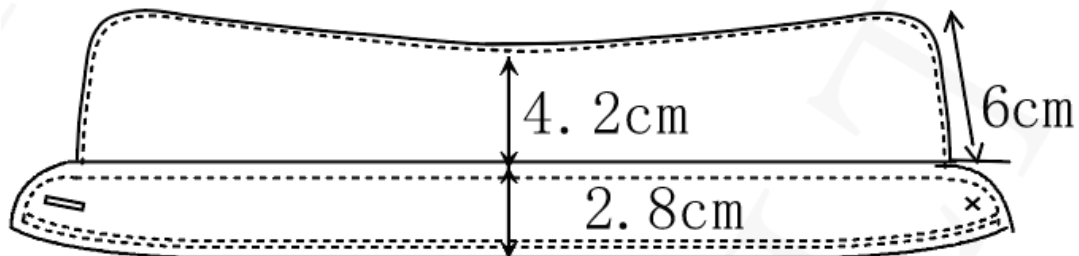

小圆角领YXL-01-01

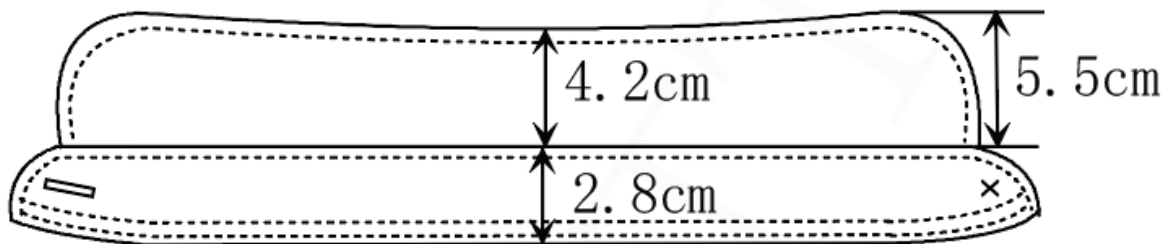

大圆角领YXL-01-02

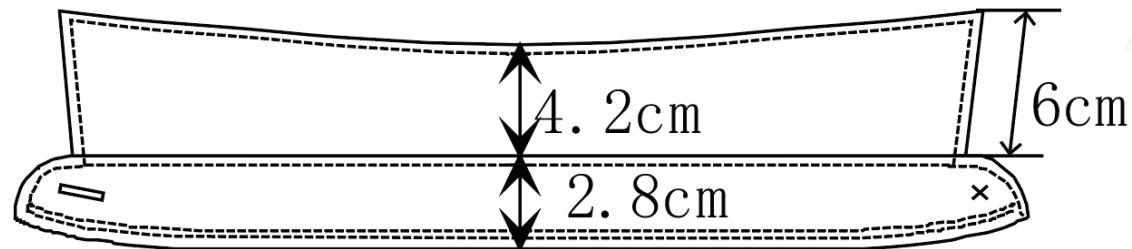

小尖领YXL-01-03

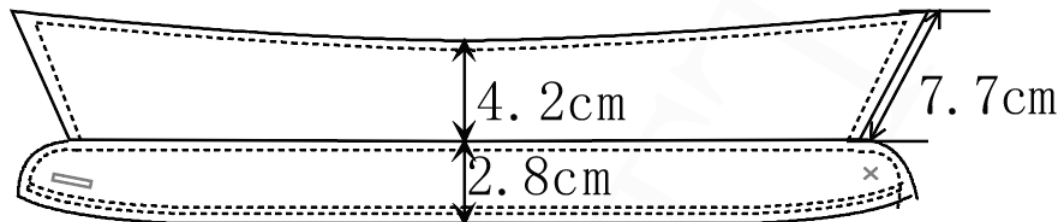

大尖领YXL-01-04

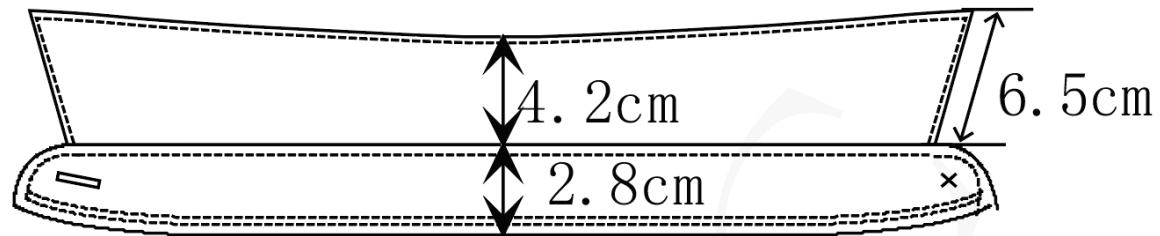

中尖领YXL-01-05

# 04: 女装衬衫缝制工艺

## (2) 领型工艺

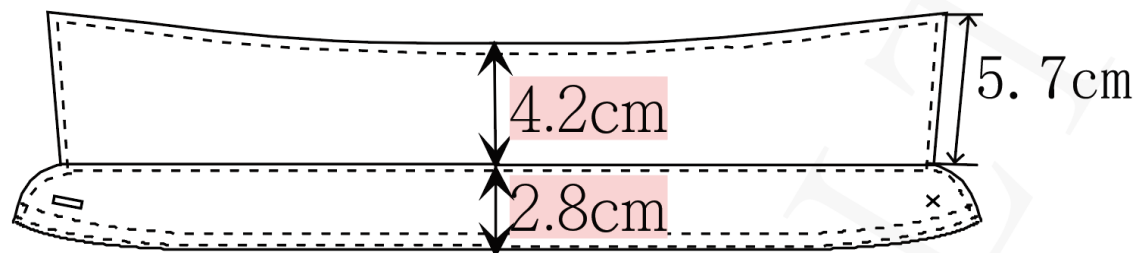

大方领YXL-01-06

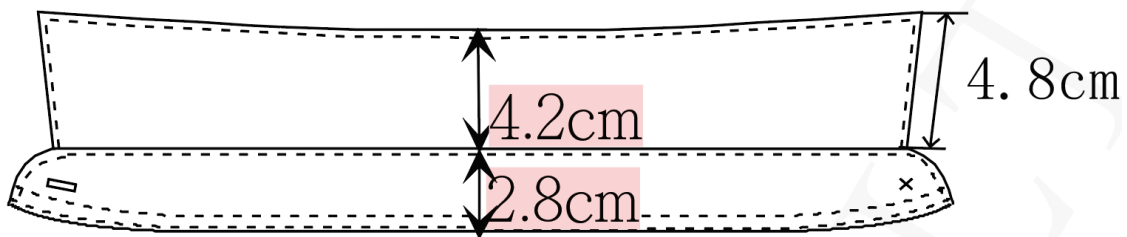

小方领YXL-01-07

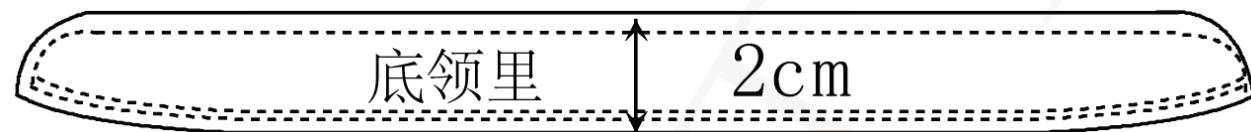

矮立领YXL-01-08

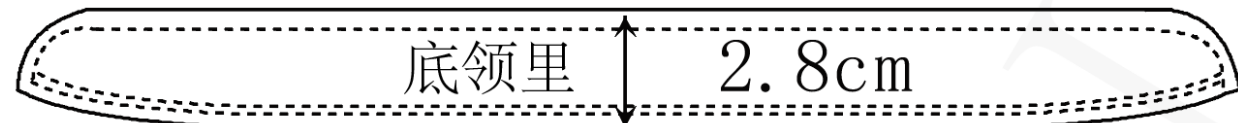

高立领YXL-01-09

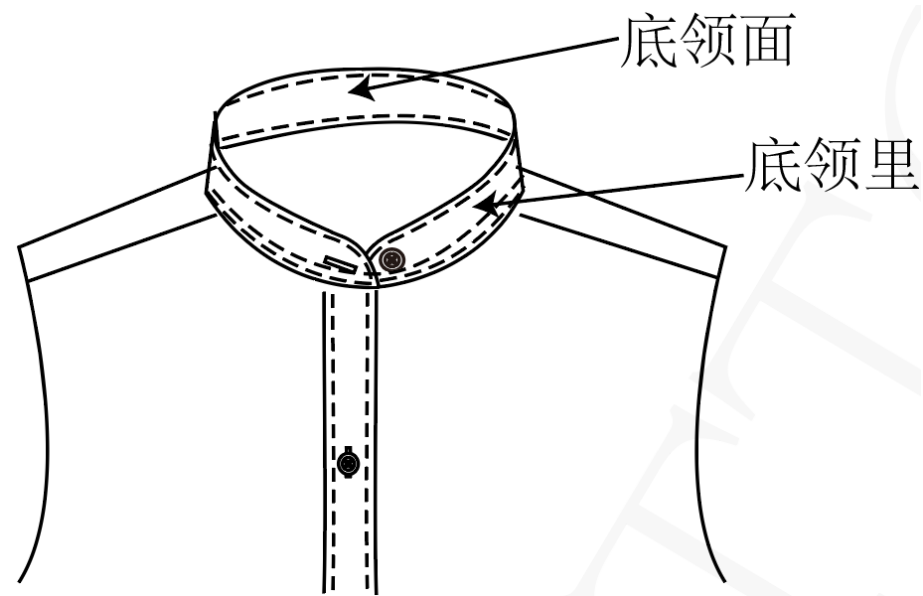

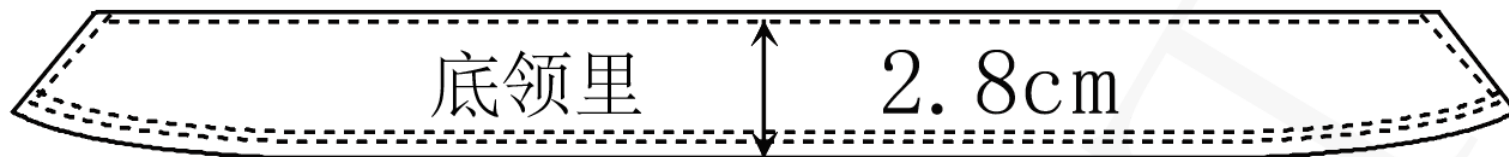

V 型立领 YXL-01-10

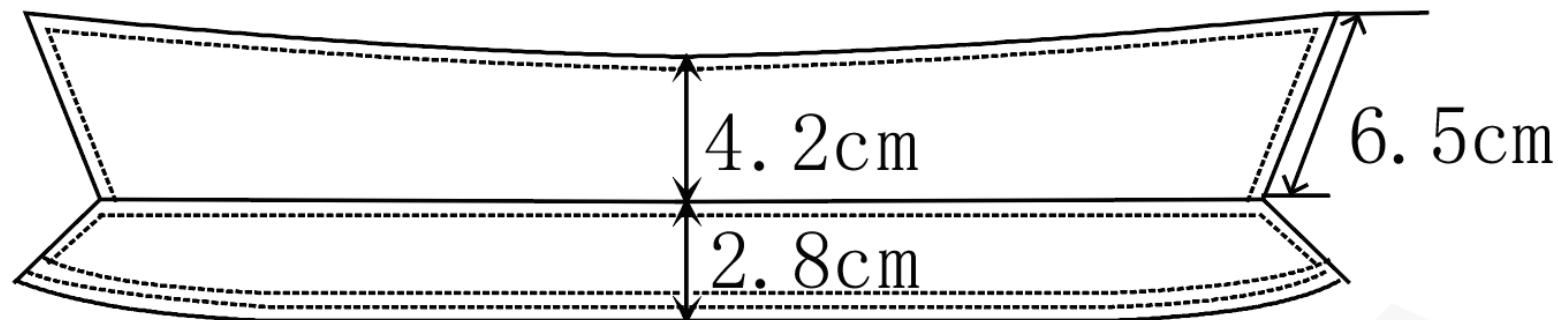

V 型尖领1 YXL-01-11

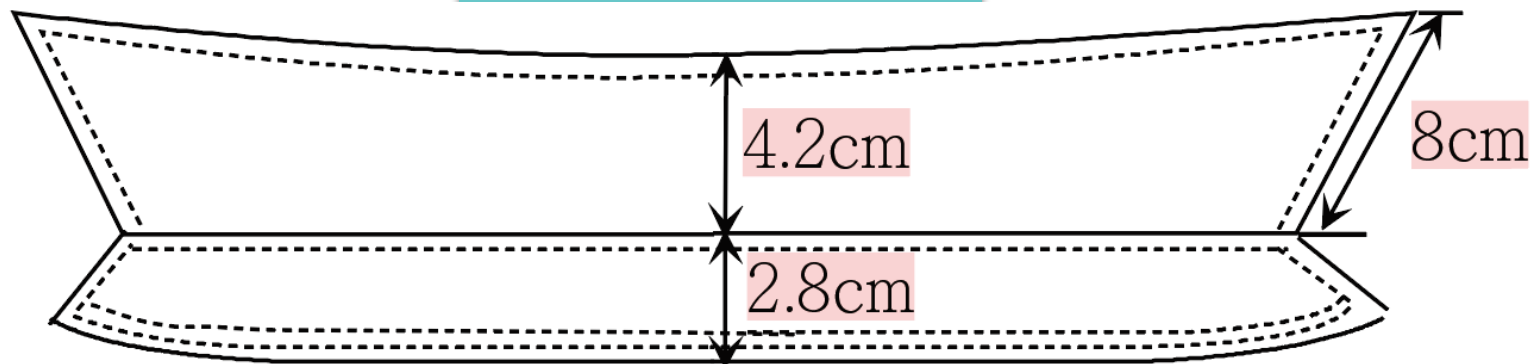

V 型尖领2 YXL-01-12

# 04: 女装衬衫缝制工艺

## (2) 领型工艺



# 04: 女装衬衫缝制工艺

## (3) 袖口工艺

### 袖头 (袖口)

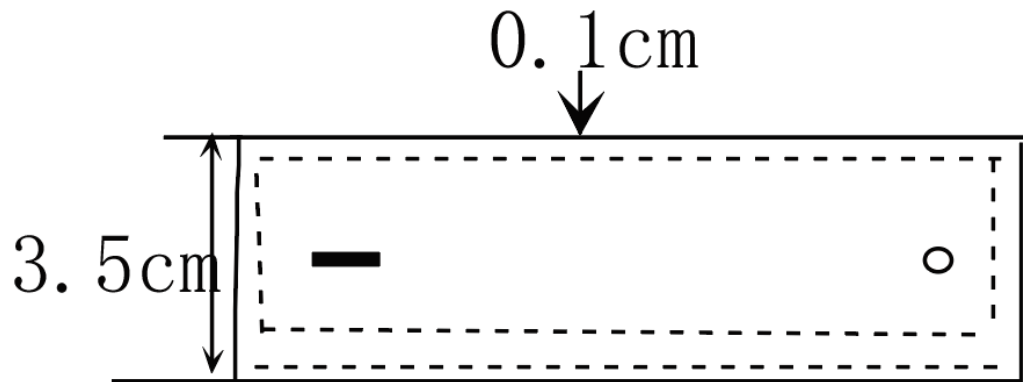

直角3.5CM一眼一扣YXL-02-01

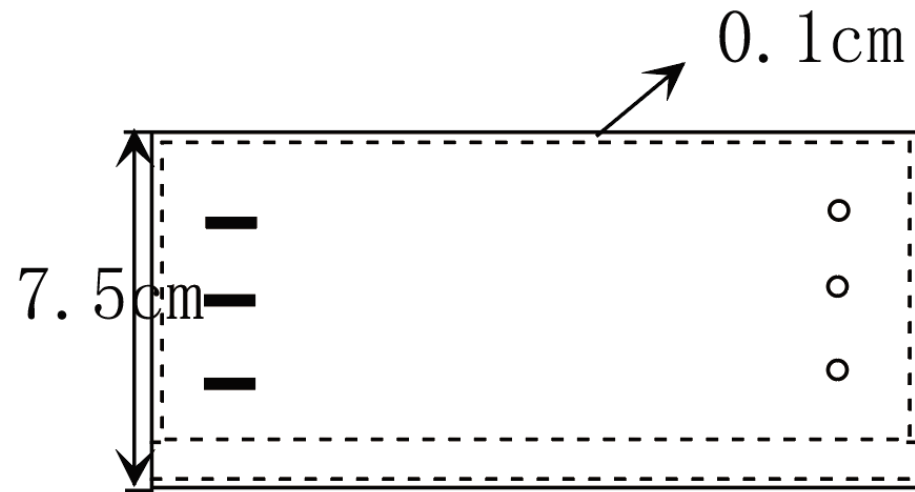

直角7.5CM三眼三扣YXL-02-03

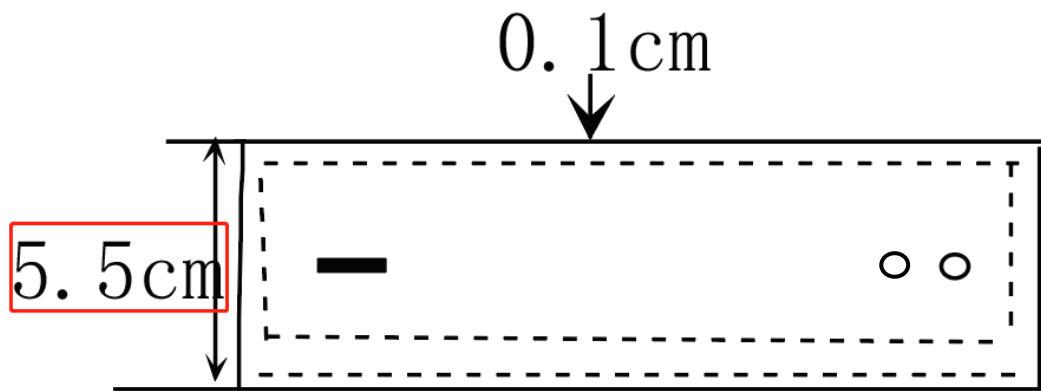

直角5.5CM一眼两扣YXL-02-02



# 04: 女装衬衫缝制工艺

(3) 袖口工艺

## 袖头 (袖口)

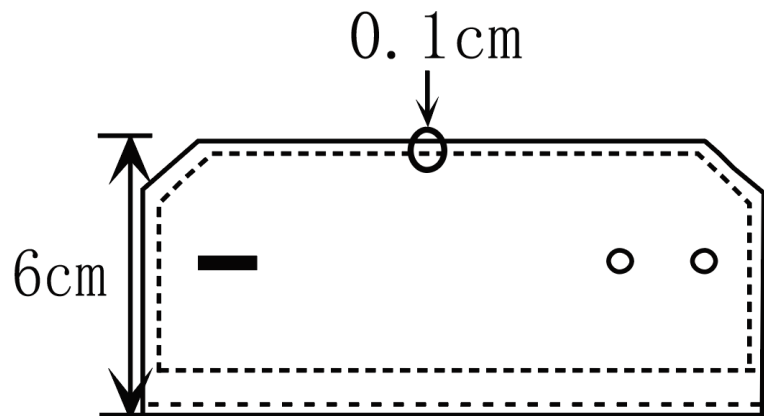

六角6CM一眼两扣YXL-02-04

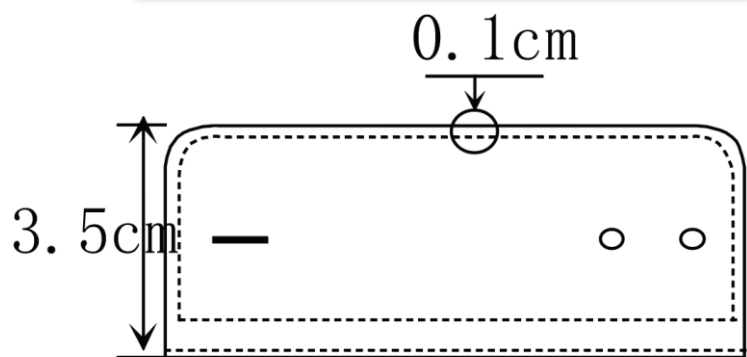

六角6CM一眼两扣YXL-02-05

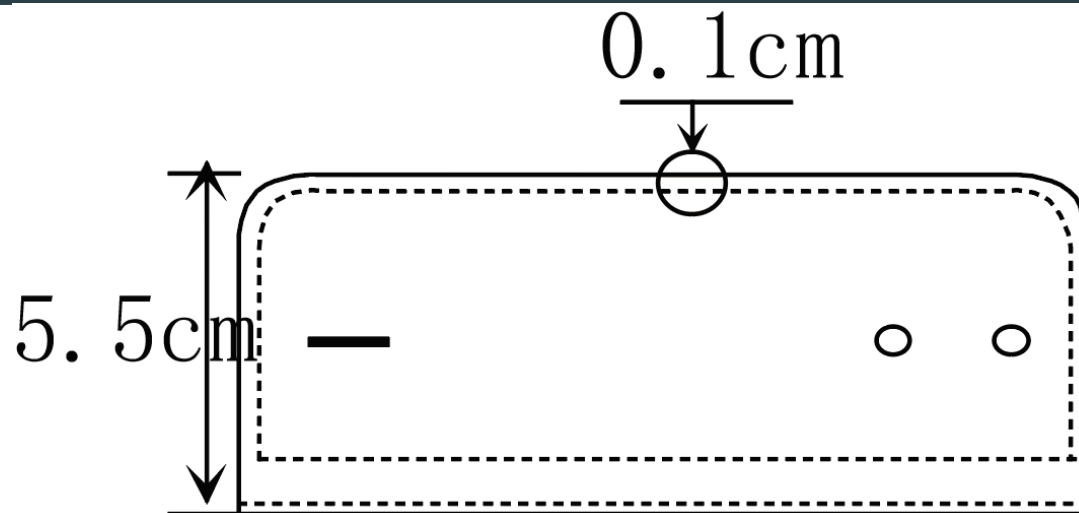
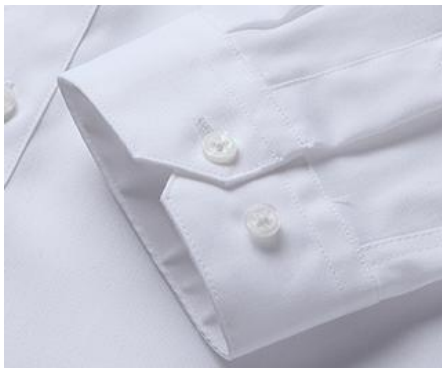

六角6CM一眼两扣YXL-02-06

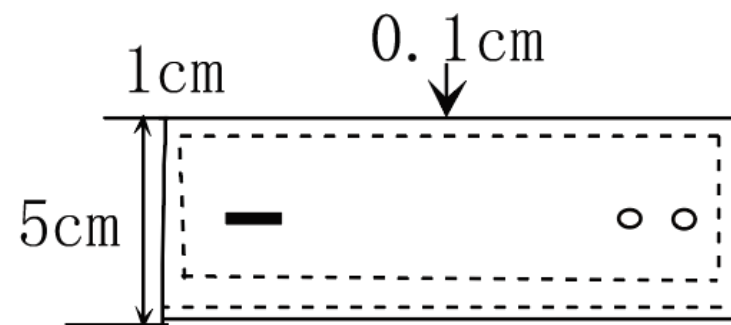

直角5cm 一眼两扣YXL-02-07

### 短袖口

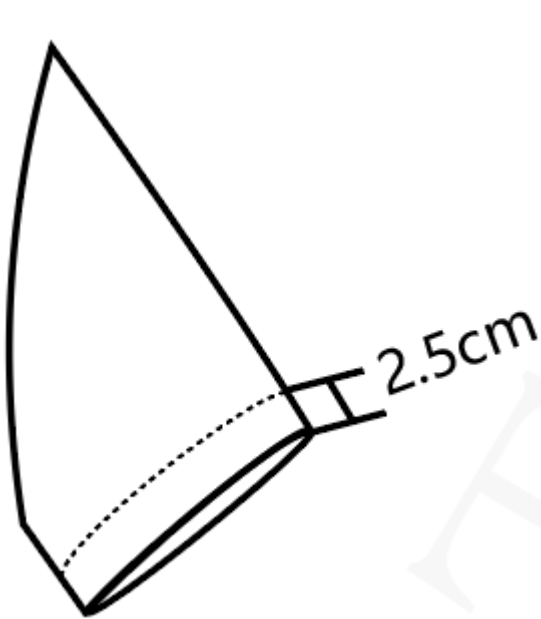

内扣短袖口YXL-51-01

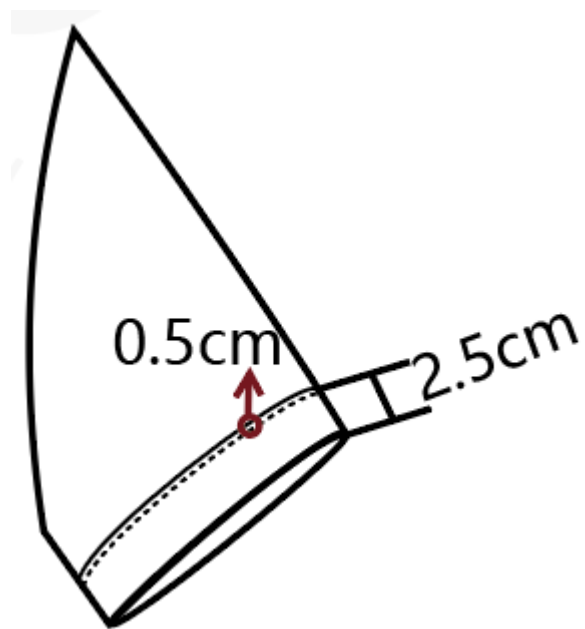

内扣外翻短袖口YXL-51-02

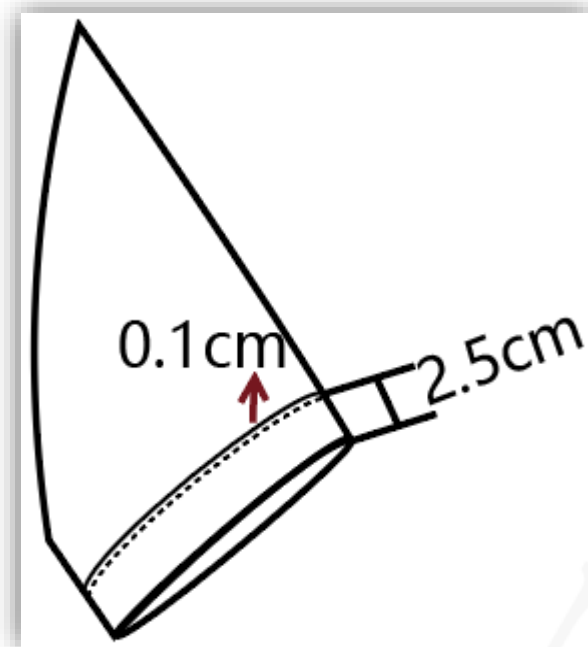

夹短袖口YXL-51-03

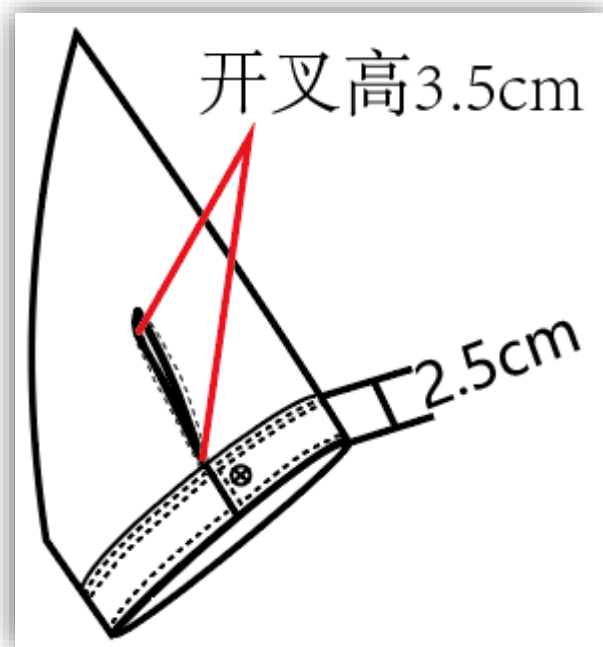

袖头式短袖口YXL-51-04 (时尚款)

### 短袖口



默认袖口



### 袖祺

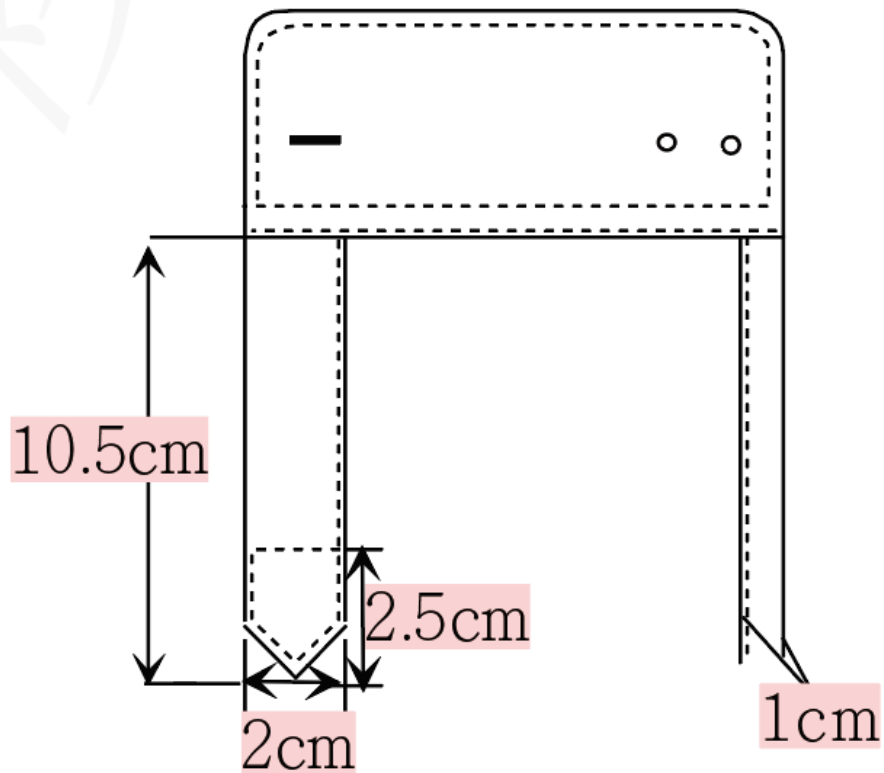

编号: YXL-60-01

### 袖褶

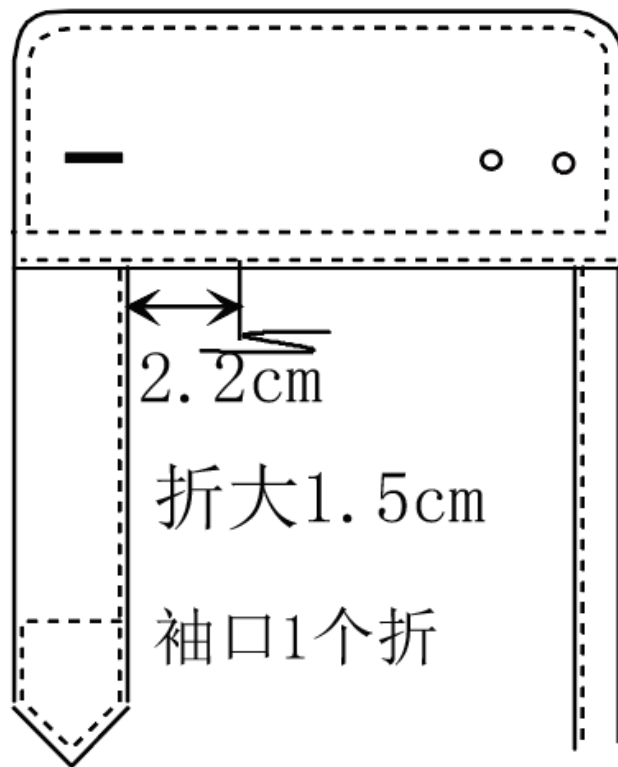

编号: YXL-120-01



# 04: 女装衬衫缝制工艺

## (4) 前片工艺设计

### 门襟

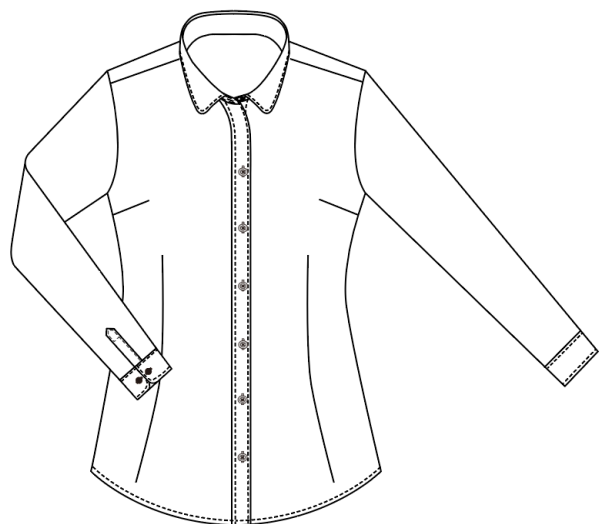

3款门襟宽度: 2.5CM  
暗门襟打结、门襟暗扣  
可以加安全扣

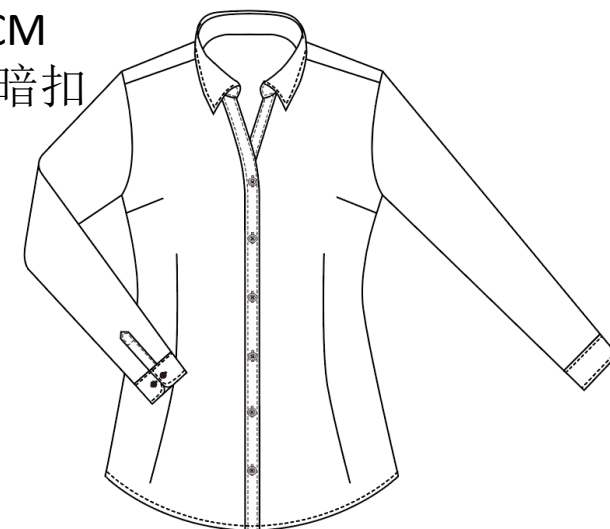

贴门襟



暗门襟

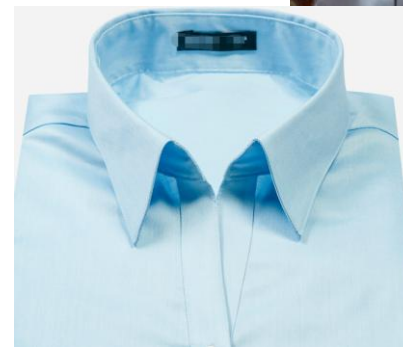

V领贴门襟



# 04: 女装衬衫缝制工艺

## (6) 主唛 (商标)、锁钉位置

YXL-08-01 主唛位置1 (默认位置)

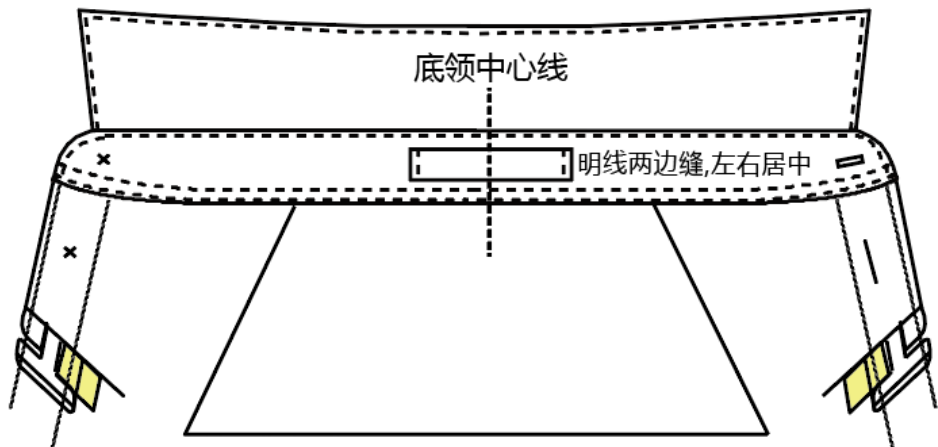

备注:唛的宽度不能超过底领中宽-1.6cm.

YXL-08-03 主唛位置3 (仅船型主唛)

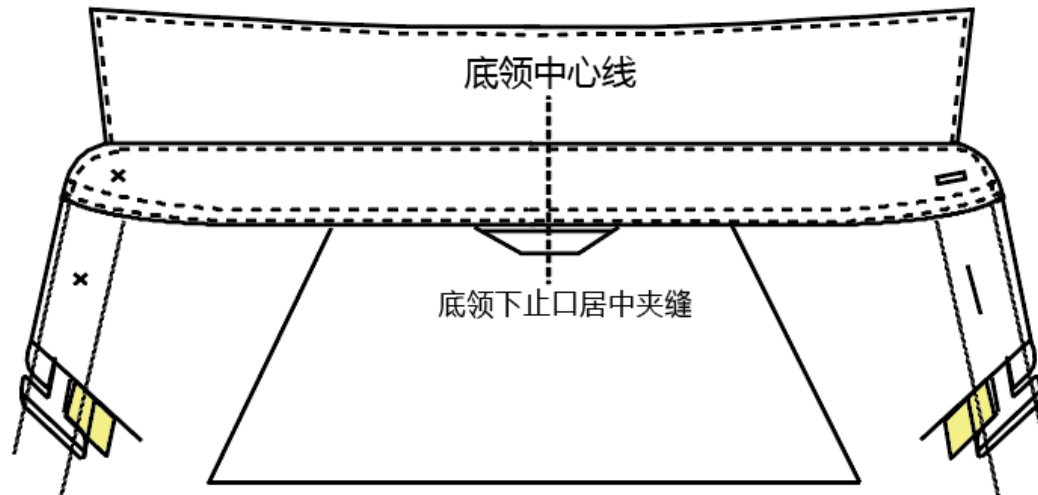

YXL-08-02 主唛位置2 (男右/女左门襟)

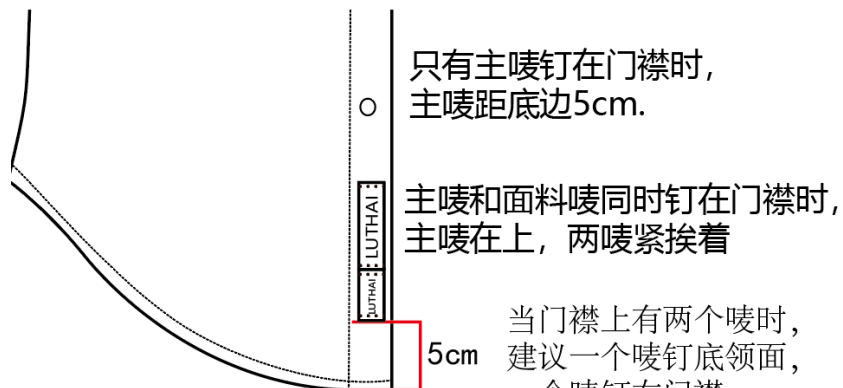

主唛位置2的主唛线迹:  
0.1cm明线,四边缝,缝透右门襟.(默认做法)

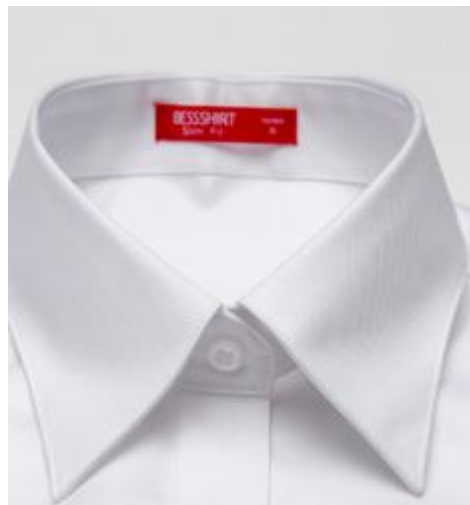

# 04: 女装衬衫缝制工艺

(6) 主唛 (商标)、锁钉位置

尺唛位置补充说明:

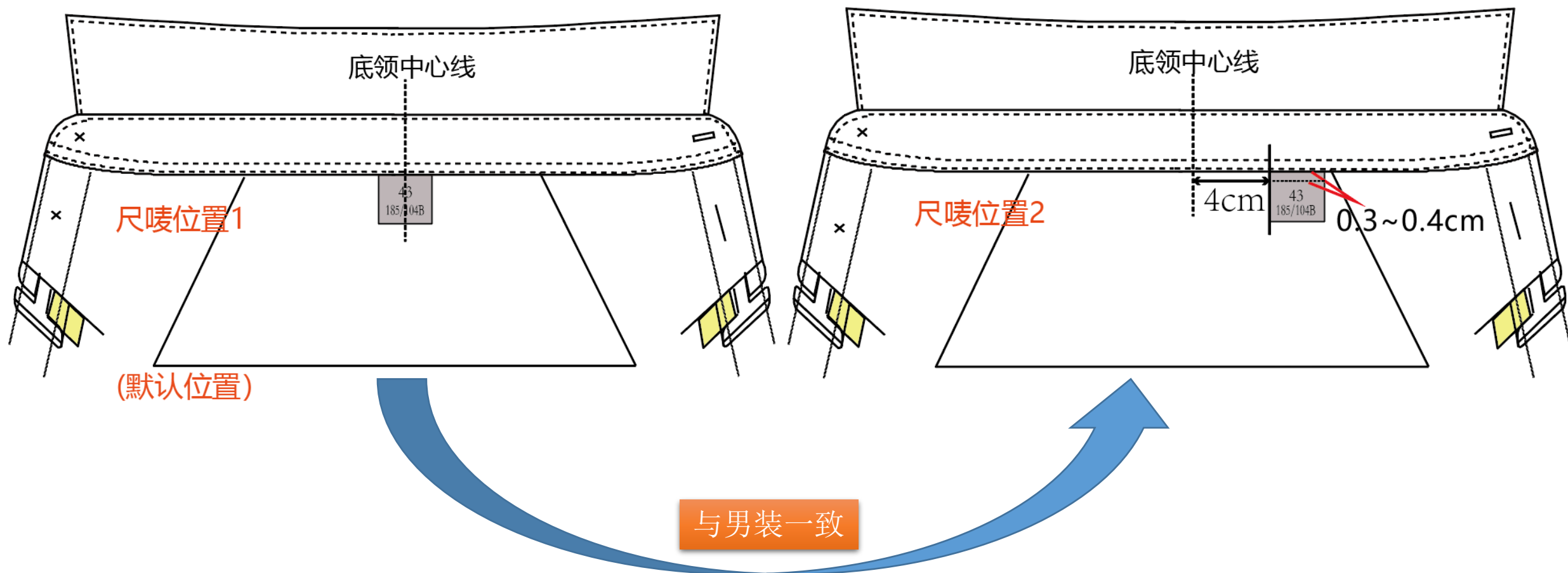



05

定制衬衫生产质量标准

## 05：定制衬衫生产质量标准

### 裁片质量要求：

- 1、面料正反面及裁剪方法符合下单要求。
- 2、裁片的款式、尺寸及特体信息与下单相符。
- 3、绣花位置、内容、颜色准确。
- 4、裁片干净，如有脏、污加以清洗，残次面料及时与客户沟通补寄面料。

### 缝制质量要求：

- 1、各部位干净整洁，无线头。
- 2、领面不允许有折痕、压痕、线印、起泡、渗胶等。
- 3、商标、号标位置端正、清楚。
- 4、各部位尺寸符合要求。
- 5、缝制线迹美观，针距符合规定。

### 整烫外观：

熨烫平服、整洁无线头，无死折、碎折，无烫黄、无水印、无变色；  
各部位花纹无变形等现象；接缝烫平，无漏烫、虚烫；后背双折整烫长短一致。

## 05: 定制衬衫生产质量标准

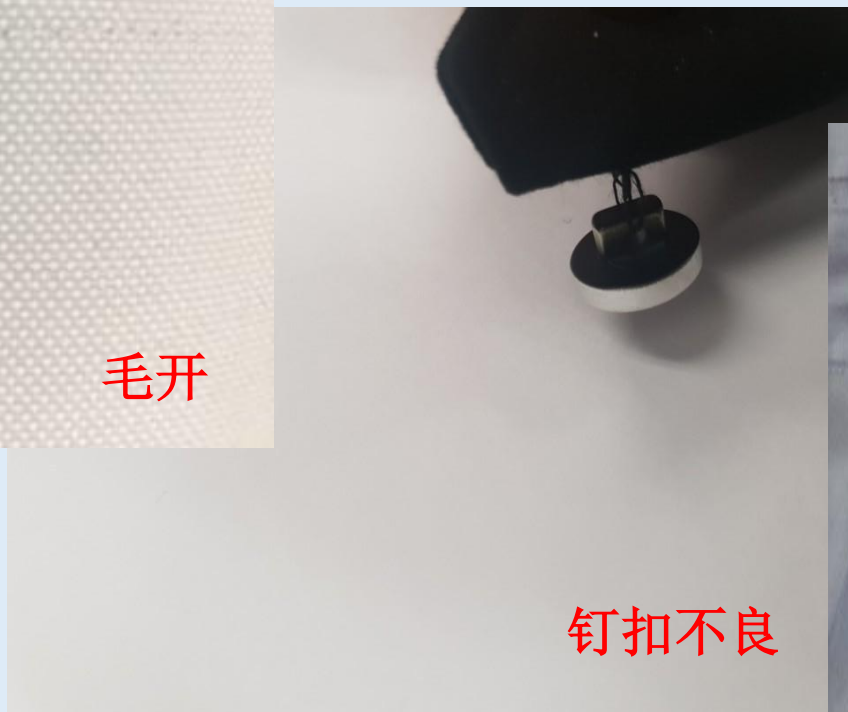

# 05: 定制衬衫生产质量标准

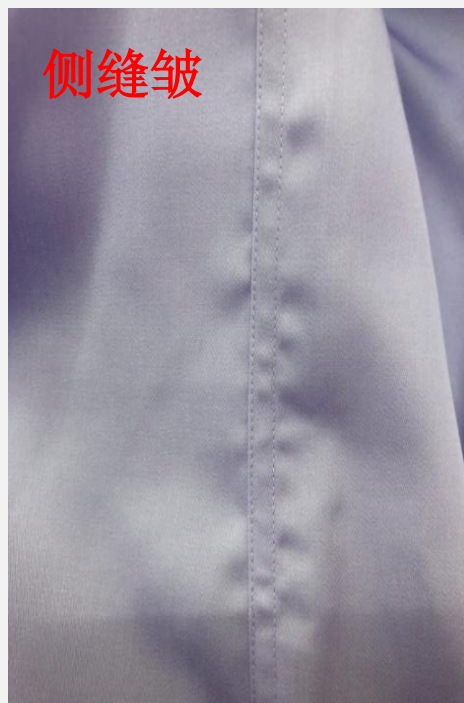

# 05: 定制衬衫生产质量标准

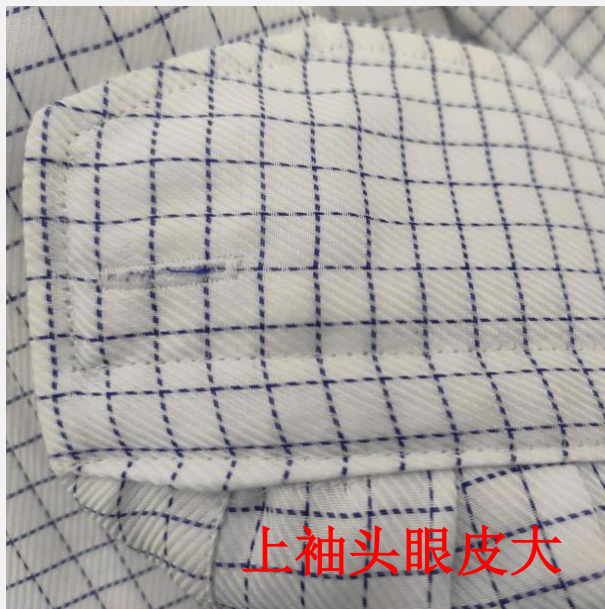

谢谢欣赏

---

